



More information on the website  
[radwag.com/us/info,w1,EMU](http://radwag.com/us/info,w1,EMU)

# PA-04/H Automatic Feeder



The drawings, photos and graphics used are for illustrative purposes only.

## Datasheet

Construction	
Protection class	IP 34
Communication interface	RS232
Power supply	100 – 240 V AC 50/60 Hz
Power consumption	95 W
Operating temperature	+5 – +40 °C
Physical parameters	
Device dimensions	229×229×303 mm
Net weight	17 kg
Gross weight	26 kg
Diameter of fed objects	ø 3 – ø 25 mm
Feeder diameter	ø 180 mm
Throughput	1 – 15 pcs/min



## Compatible with

XA 5Y.A Analytical Balance  
Antivibration tables  
XA 5Y.M.A Microbalance

RS 232, RS 485 cables  
XA 5Y Analytical Balance  
XA 5Y.M Microbalance

## Device dimensions

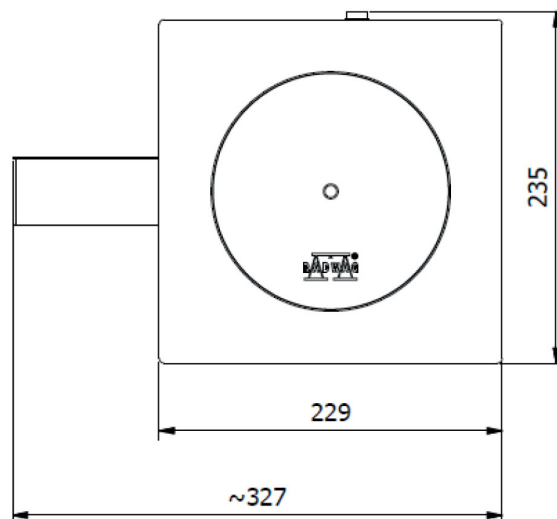
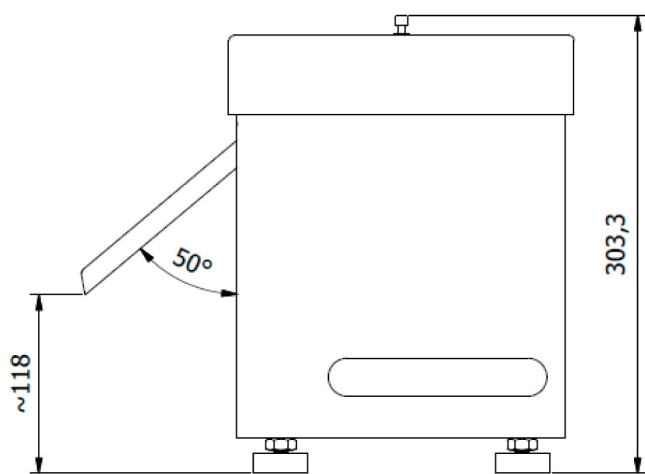

[PA-04/H Automatic Feeder](#)