

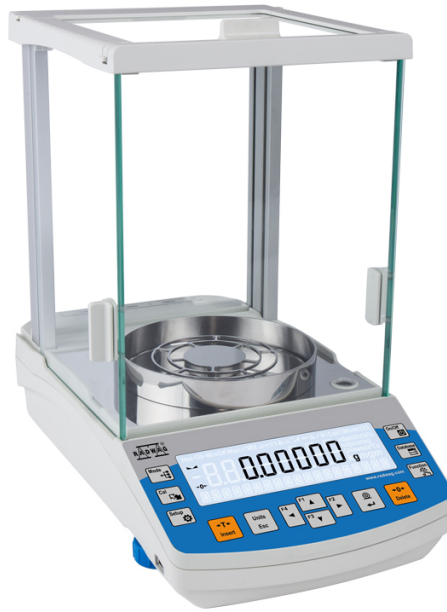

More information on the website
radwag.com/us/info,w1,DP0

AS 62.R2 PLUS Analytical Balance



The drawings, photos and graphics used are for illustrative purposes only.

Functions



Under-pan weighing

Datasheet

Maximum capacity [Max]	62 g
Minimum load	1 mg
Readability [d]	0,01 mg
Verification unit [e]	1 mg
Tare range	-62 g
Standard repeatability [5% Max]	0,012 mg
Standard repeatability [Max]	0,02 mg
Standard minimum weight (USP)	24 mg
Standard minimum weight (U=1%, k=2)	2,4 mg
Permissible repeatability [5% Max]	0,02 mg
Permissible repeatability [Max]	0,035 mg

Linearity	±0,05 mg
Stabilization time	2 s
Adjustment	internal (automatic)
OIML Class	I
Physical parameters	
Leveling system	manual
Display	LCD (backlit)
Weighing chamber doors	manual
Delivery components	Balance, weighing pan, weighing pan shield, centring ring, bottom cover, power supply, fabric dust cover.
Weighing pan dimensions	ø90 open-work pan + ø85 (option) mm
Packaging dimensions	545×455×575 mm
Net weight	6,98 kg
Gross weight	10,5 kg
Construction	
Protection class	IP 43
Communication interface	2×RS232 ¹ , 2×USB-A (interchangeable), USB-B, Wi-Fi (option)
Power supply	Adapter: 100 – 240V AC 50/60Hz 0,6A; 12V DC 1,2A Balance: 12 – 15V DC 0,4A max
Power consumption max.	3 W
Operating temperature	+10 – +40 °C
Relative humidity	40% – 80%

Repeatability is expressed as a standard deviation from 10 weighing cycles.

Stabilization time depends on the ambient conditions and the dynamics of weighing pan loading; specified for FAST profile.

¹ Barcode scanners, available as weighing instrument accessory, communicate with the instrument via RS232 interface exclusively.

* Wi-Fi® is a registered trademark of Wi-Fi® Alliance.



Extra payment for verification



Accessories

Antivibration tables
Power Adapters
Cigarette lighter receptacle power supply cables
Density determination KIT
USB cable (scale - printer)
Professional Weighing Tables
Barcode scanners
Workstation for pipettes calibration
RS 232, RS 485 cables

Displays
Protective cover for balances
Weighing dishes
Antistatic ionizer
Receipt Printer
RS 232, RS 485 cables
Under-pan weighing
RS 232 cables (scale - printer)

Software

• RAD Key [WX-010-0005]

• R Panel [WX-010-0187]

Device dimensions

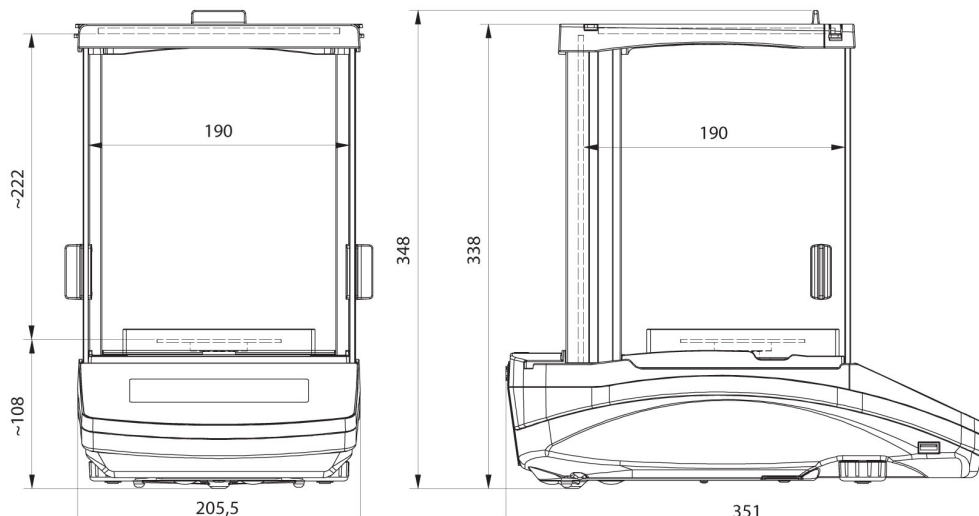

AS R2, d = 0.01 mg

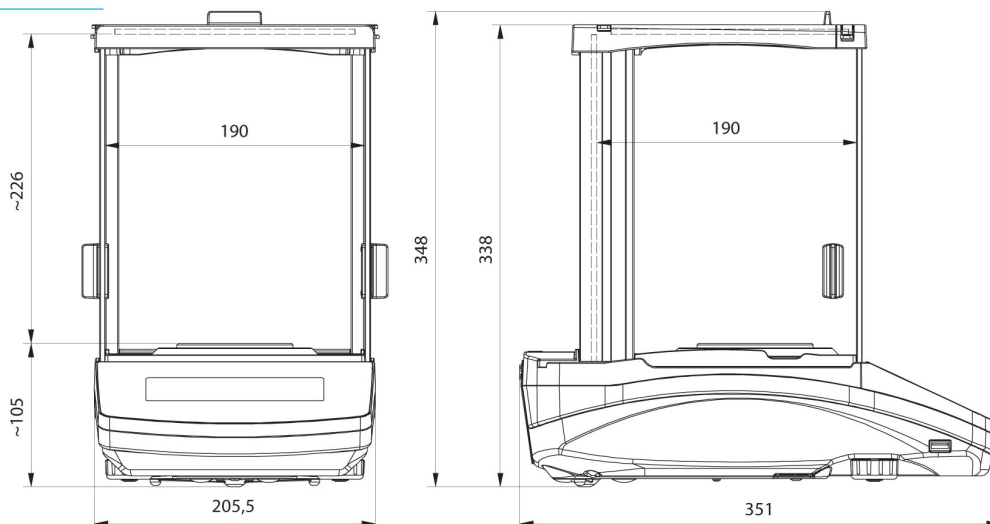

AS R2, AS R1 d = 0.1 mg