



More information on the website
radwag.com/us/info,w1,CYJ

WAY 100.5Y.KO Mass Comparator



The drawings, photos and graphics used are for illustrative purposes only.

Datasheet

E1	5 g ÷ 100 g
E2	100 mg ÷ 100 g
F1	1 mg ÷ 100 g
F2	1 mg ÷ 100 g
M1	1 mg ÷ 100 g
M2	1 mg ÷ 100 g
Maximum capacity [Max]	110 g
Readability [d]	0,001 mg
Standard repeatability [5% Max]	2,5 µg
Standard repeatability [Max]	3 µg
Permissible repeatability	5 µg
Eccentricity (tested load)	0 mg*
Electric compensation range	-1 g ÷ +10 g
Stabilization time	30 s
Adjustment	internal

Physical parameters	
Display	10" graphic colour touchscreen
Weighing pan dimensions	ø30 mm
Weighing device dimensions	385×217×524 mm
Controlling device dimensions	249×170×72 mm
Anti-draft chamber dimensions	560×340×570 mm
Packaging dimensions	945×820×1260 mm
Chamber packaging size	820×850×630 mm
Net weight	36,5 kg
Gross weight	56,5 kg
Supplementary weights internal	automatic
Supplementary weights external	10 g
Communication interface	2×USB-A, USB-C, HDMI, Ethernet, Wi-Fi, Hotspot
Operating temperature	+15 ÷ +30 °C
Operating temperature change rate	±0,5°C/12h (±0,3°C/4h)
Relative humidity	40% ÷ 60%
Relative humidity change rate	± 3 % / 4 h

* Wi-Fi® is a registered trademark of Wi-Fi® Alliance.



Accessories

RFID Tags	Label Printers
Antivibration tables	THBR 2.0 System - Ambient Conditions Monitoring
Suspended Self-Centring Weighing Pan for WAY 5Y.KO Manual Mass Comparator	Receipt Printer
Additional modules	Fingerprint Reader
Protective cover for balances	RS 232, RS 485 cables
Barcode scanners	RS 232 cables (scale - printer)
RS 232, RS 485 cables	

Software

- RAD Key [WX-010-0005]
- RMCS System Network Management of Calibration Process [WX-010-0048]
- RMCS Lite [WX-010-0164]

Device dimensions



WAY 5.5Y.KO



WAY 100.5Y.KO

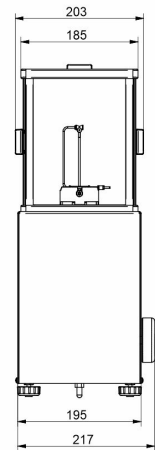

WAY 1200.5Y.KO



WAY 5100.5Y.KO

