

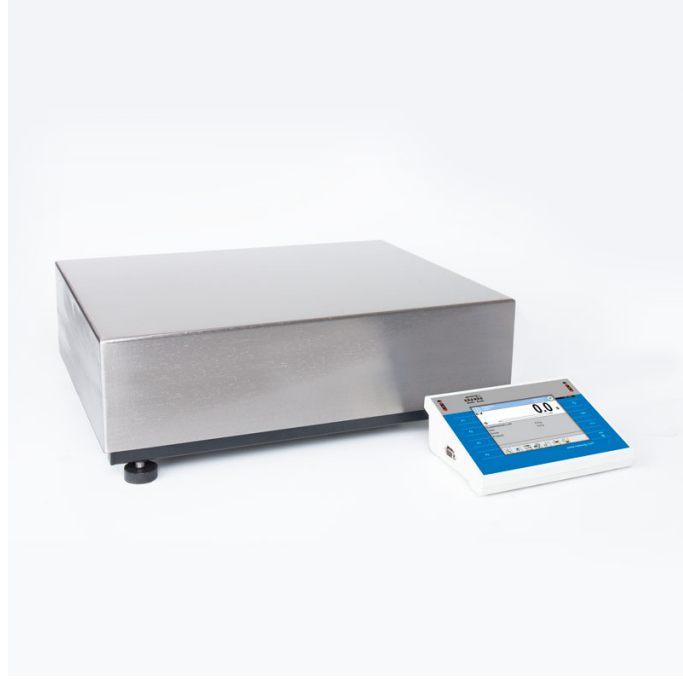

More information on the website  
radwag.com/tr/info,w1,CSH

# PUE 7.1.120.2.HRP Yüksek Çözünürlüklü Terazi



The drawings, photos and graphics used are for illustrative purposes only.

## Teknik Veriler

Metrolojik parametreler	
Maksimum yük [Max]	120 kg
Minimum yük [Min]	50 g
Ön yük	30 kg
Okuma içingruluđu [d]	0,5 g
Dara aralıđı	-120 kg
Tekrarlanabilirlik	0,3 g
Dođrusallık	±2 g
Kararlılık süresi	3 s
Ayarlama	dahili (otomatik)
Fiziksel parametreler	
Display	5,7" dirençli renkli dokunmatik ekran
Tartım kefi boyutları	500x500 mm
Konstrüksiyon	
IP Sınıfı	IP 66/67 konstrüksiyon, IP 43 terminal

Konstrüksiyon	
Konstrüksiyon	toz kaplı çelik St3S
Tartım kefesi	Paslanmaz çelik AISI304
Haberleşme arayüzler	
Haberleşme arayüzü	2×RS232, 2×USB-A, Ethernet, 4 IN / 4 OUT (dijital), Wi-Fi
Elektrik parametreleri	
Güç kaynağı	100 – 240 V AC 50/60 Hz
Çevresel koşullar	
Çalıştırma sıcaklığı	+10 ÷ +40 °C
Atmosferik nem	40% ÷ 80%

\* Wi-Fi® is a registered trademark of Wi-Fi® Alliance.



## Aksesuarlar

### Display

Transponder kart okuyucular  
RS 232 cables (scale - Ethernet)  
RS 232 cables (scale - printer)  
Barkod okuyucu

### Etiket Yazıcısı

Fiş yazıcı  
Modülleri ek platformları  
RS 232 – USB Converter

## Yazılım

- E2R Tartım [WX-010-0099]
- RAD Key [WX-010-0005]
- RADWAG Remote Desktop [WX-010-0107]
- Terazi Editörü - EWAG 2.1 [WX-010-0173]

- E2R Tartı Kayıtları [WX-010-0038]
- Etiket Editörü R02 [WX-010-0094]
- R-Lab [WX-010-0080]
- RADWAG Development Studio [WX-010-0104]

## Cihaz boyutları

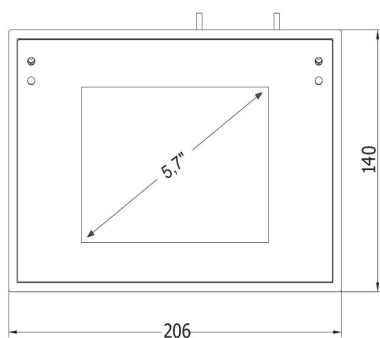
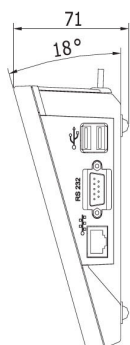
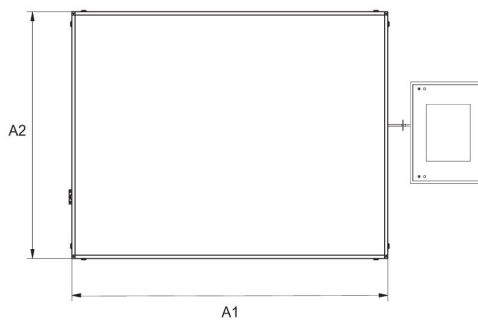
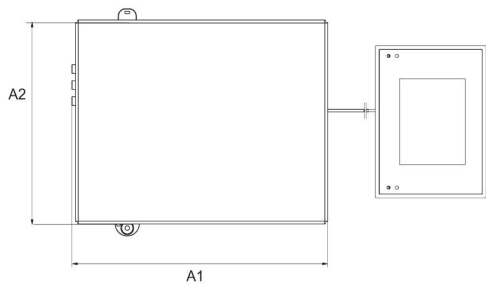
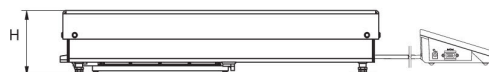
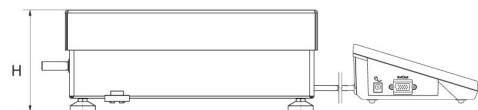

Scale type	A1	A2	H
PUE7.1.16 - 32.HRP	360	280	139±3
PUE7.1.62 - 120.HRP	500	500	175±3
PUE7.1.150 - 300.HRP	800	600	175±3
PUE7.1.300.1 - 1100.HRP	1000	800	175±3
PUE7.1.2000.HRP	1250	1000	175±3

dimensions in mm