



More information on the website
radwag.com/de/info,w1,COV

Multifunktionswaage HX7.6/15.H2



The drawings, photos and graphics used are for illustrative purposes only.

Funktionen



Dosing



Percent Weighing



Parts counting



Formulation



Replaceable unit



ALIBI Memory

Technische Daten

Messtechnische Parameter	
Wägebereich [Max]	6 / 15 kg
Min. Belastung	40 / 100 g
Zifferschritt [d]	2 / 5 g
Eichwert [e]	2 / 5 g
Tarierbereich	-6 / -15 kg
OIML-Klasse	III
Physikalische Parameter	
Display	7" grafisch farbiger
Waagschale	250×300 mm

Physikalische Parameter	
Verpackungsgröße	310×370×460 mm
Nettogewicht	10,2 kg
Bruttogewicht	12,7 kg
Konstruktion	
Schutzart	IP 67 Konstruktion, IP 66 / 68 Messgerät
Tastatur	membran
Konstruktion	Edelstahl AISI304
Waageschale	Edelstahl AISI304
Kommunikationsschnittstellen	
Schnittstellen	RS232, USB-A, 4IN, 4OUT, Ethernet, Modbus RTU
Optionale Schnittstellen	USB (M12 4P), Ethernet, Modul RS485, Modul RS232, Modul Profibus (Dp SLAVE), PROFINET (RRJ45), EtherNet/IP (RRJ45), 12 IN, 12 OUT, 4-20mA, 0-10V
Elektrische Parameter	
Stromversorgung	100 – 240 V AC 50/60 Hz
Maximaler Leistungsaufnahme	25 W
Optionale Stromversorgung	12 – 24 V DC
Umgebungsbedingungen	
Umgebungstemperatur	-10 – +40 °C
Lagertemperatur	-10 – +50 °C
Relative Luftfeuchtigkeit	10% – 80% RH ohne Kondensation
Messgerät	PUE HX7
Anzahl von Tasten	22
Besonderheiten	
Max. Anzahl der Plattformen	2



Extra payment for verification



Zubehör

Kabel RS 232 (Waage – Drucker)
 Rahmen mit Rollenförderern
 Kabel RS 232 (Waage – Drucker ZEBRA)
 Displays
 Netzteile
 Kabel RS 232, RS 485
 USB-Kabel (Waage – Drucker)
 E/A Kabel
 Barcode-Scanner

Etikettendrucker
 Wandhalterung, Stativ
 Tastaturen, Taster
 USB-Adapter
 Thermische Drucker
 Modul für zusätzliche Wägeplattformen
 Konverter RS 232 – USB
 Zusätzliche Module

Software

- E2R Wägung [WX-010-0099]
- RAD Key [WX-010-0005]
- Alibi Reader [WX-010-0114]
- Scale Editor 2.1 [WX-010-0173]

- E2R Evidenz [WX-010-0038]
- Etiketten-Editor R02 [WX-010-0094]
- RLAB [WX-010-0080]
- RADWAG Development Studio [WX-010-0104]

Abmessungen des Gerats

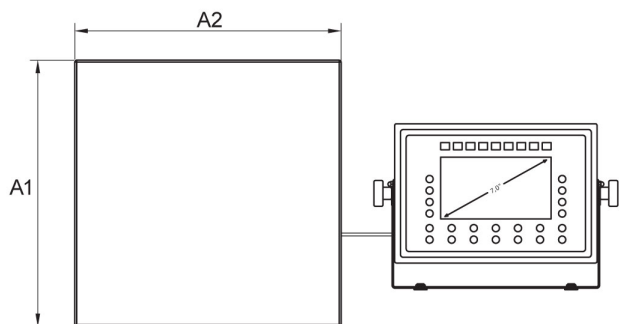
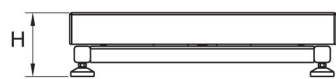

H Platform

	A1	A2	H
HX7.H1	200	150	85±3
HX7.H2	250	300	103±3
HX7.H3	410	410	98±2
HX7.H4	500	500	155±5
HX7.H3/5	400	600	155±5
HX7.H5	600	600	155±5
HX7.H6	800	800	135±5

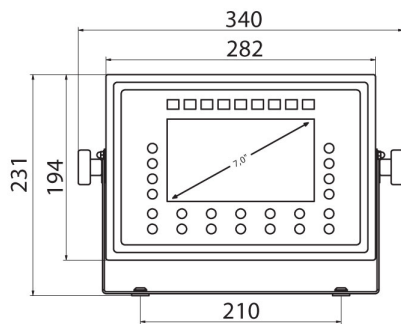
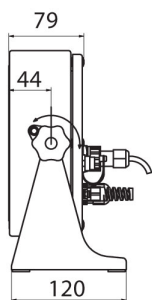

PUE HX7