

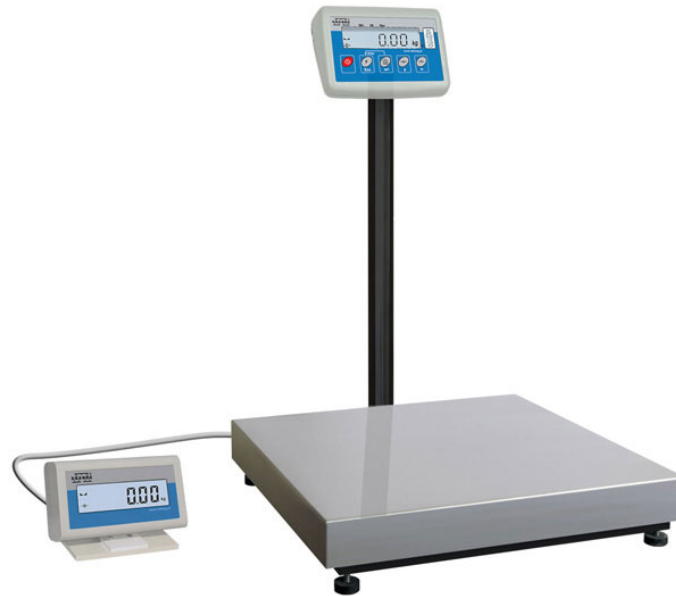

More information on the website
radwag.com/en/info,w1,CBT

C315.P.60 Postal Scale for Packages



The drawings, photos and graphics used are for illustrative purposes only.

Functions

 Plus/Minus Control

 Percent Weighing

 Totalizing

 Parts counting

 Internal battery

 Peak hold

 Newton unit measurement

 GLP Procedures

 Animal weighing

 ALIBI Memory

Datasheet

| Metrological parameters | |
|--|--------|
| Maximum capacity [Max] | 60 kg |
| Minimum load | 100 g |
| Readability [d] | 20 g |
| Verification unit [e] | 20 g |
| Tare range | -60 kg |
| Max readability for non-verified scale | - |
| OIML Class | III |

| Physical parameters | |
|-----------------------------|-------------------------------------|
| Display | LCD (backlit) |
| Weighing pan dimensions | 400×500 mm |
| Packaging dimensions | 720×620×210 mm |
| Net weight | 15.5 kg |
| Gross weight | 17.8 kg |
| Construction | |
| Protection class | IP 65 construction, IP 43 terminal |
| Construction | mild steel St3S |
| Weighing pan material | Stainless steel AISI304 |
| Communication interface | |
| Communication interface | RS232 |
| Optional interfaces | RS232 |
| Electrical parameters | |
| Power supply | 100 – 240 V AC 50/60 Hz and battery |
| Power consumption max. | 5 W |
| Operation time on batteries | max 8h |
| Environmental conditions | |
| Operating temperature | 0 ÷ +40 °C |
| Storage temperature | -10 ÷ +50 °C |
| Relative humidity | 10% ÷ 85% RH no condensation |
| Indicator | C315 |



Extra payment for verification



Accessories

RS 232 cables (scale - printer)
Cigarette lighter receptacle power supply cables
Displays
RS 232 – Ethernet Converter
AP2-1 Current Loop Unit

RS 232, RS 485 cables
RS 232 – USB Converter
RS 232 cables (scale - printer)
RS 232 – RS 485 Converter
Receipt Printer

Software

• RAD Key [WX-010-0005]
• R-Lab [WX-010-0080]

• R-Panel [WX-010-0187]
• Scale Editor 2.1 [WX-010-0173]

Device dimensions

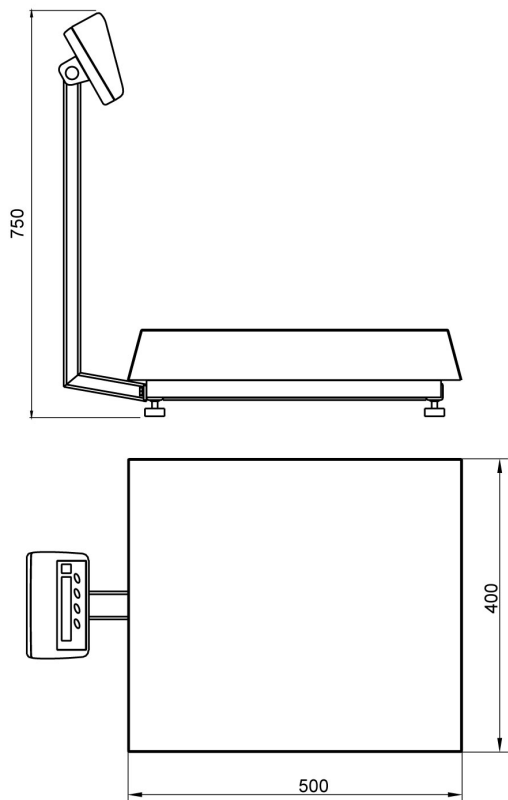

C315.P.60