



SDKP Workstation for Pipettes Calibration

More information on the website
radwag.com/en/info,w1,CB2



The drawings, photos and graphics used are for illustrative purposes only.

Datasheet

Physical parameters	
Delivery components	table for calibration, anti-vibration table, probe for temperature, humidity and pressure measurement, probe for water temperature measurement, sink for used water, armrests, LCD monitor, PC with pre-installed software PIPETTES RADWAG, power supply, keyboard and mouse, container for used water
Packaging dimensions	820x1160x890 mm
Length	1100 mm
Width	750 mm
Height	1100 mm
Number of workstations	1

Compatible with

XA 5Y.M.A.P Microbalance for pipettes calibration
Microbalance for Pipette Calibration MYA 5Y.P
AS X7 Analytical Balance
AS X2 PLUS Analytical Balances
Pipette Tips

AS 5Y Analytical Balance
AS R2 PLUS Analytical Balance
AS R1 PLUS Analytical Balance
THBR 2.0 System - Ambient Conditions Monitoring

Device dimensions

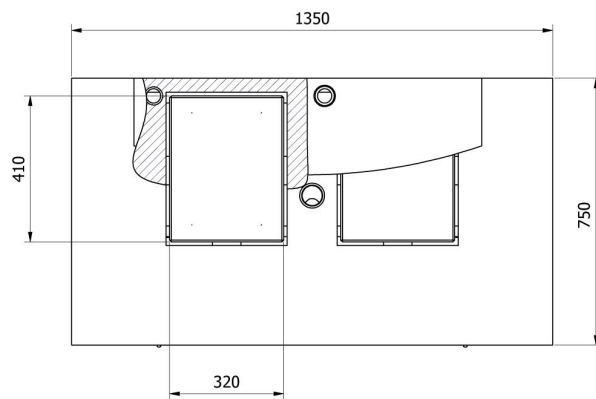
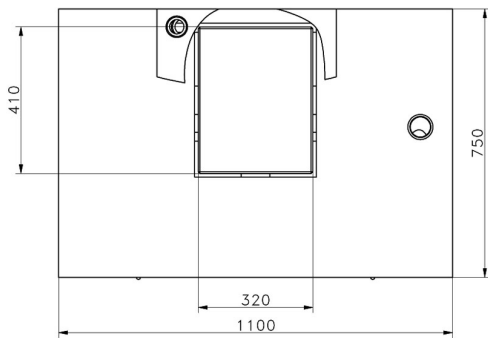
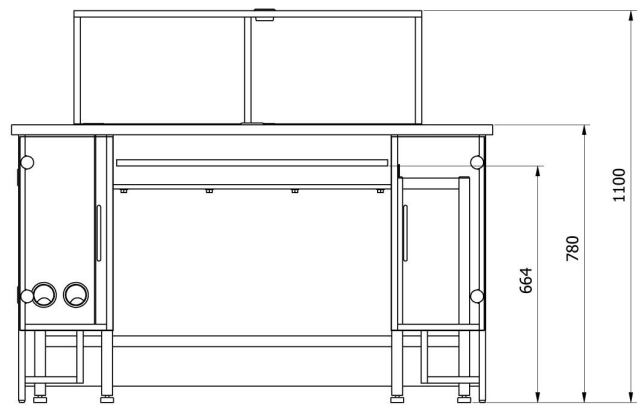
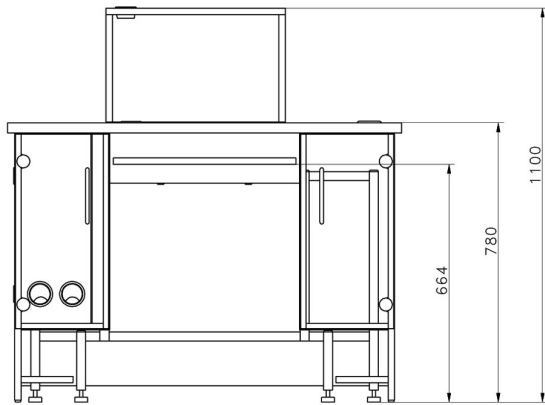

—SDKP

—SDKP DUAL