



More information on the website  
radwag.com/us/info,w1,C03

# PS 750.R2.H Precision Balance



The drawings, photos and graphics used are for illustrative purposes only.

## Functions



Autotest



Dosing



Percent Weighing



Totalizing



Parts counting



Peak hold



Newton unit measurement



Statistics



Checkweighing



GLP Procedures



Animal weighing



Density determination

## Datasheet

Maximum capacity [Max]	750 g
Minimum load	20 mg
Readability [d]	0,001 g
Tare range	-750 g
Repeatability (Max)	0,0015 g
Repeatability (5% Max)	0,0005 g
Linearity	±0,003 g
Stabilization time	2 s

Adjustment	internal (automatic)
Sensitivity temperature drift	$2 \times 10^{-6} / ^\circ\text{C} \times \text{Rt}$
<b>Physical parameters</b>	
Leveling system	manualny
Display	LCD (backlit)
Weighing pan dimensions	ø100 mm
Packaging dimensions	475×380×345 mm
Net weight	3,5 kg
Gross weight	5,5 kg
<b>Construction</b>	
Protection class	IP 54
Communication interface	2×RS232 <sup>1</sup> , USB-A, USB-B, Wi-Fi (option)
Power supply	Adapter: 100 – 240V AC 50/60Hz 0,6A; 12V DC 1,2A Balance: 12 – 15V DC 0,4A max
Power consumption	4 W
Operating temperature	+10 ÷ +40 °C
Relative humidity	40% ÷ 80%

\* Wi-Fi® is a registered trademark of Wi-Fi® Alliance.



## Accessories

Antivibration tables  
Power Adapters  
Cigarette lighter receptacle power supply cables  
USB cable (scale - printer)  
Barcode scanners  
RS 232, RS 485 cables

Displays  
Receipt Printer  
RS 232, RS 485 cables  
Protective cover for balances  
Under-pan weighing  
RS 232 cables (scale - printer)

## Software

- RAD Key [WX-010-0005]
- Alibi Reader PC Software [WX-010-0114]

- R Panel [WX-010-0187]
- RADWAG Development Studio [WX-010-0104]

## Device dimensions

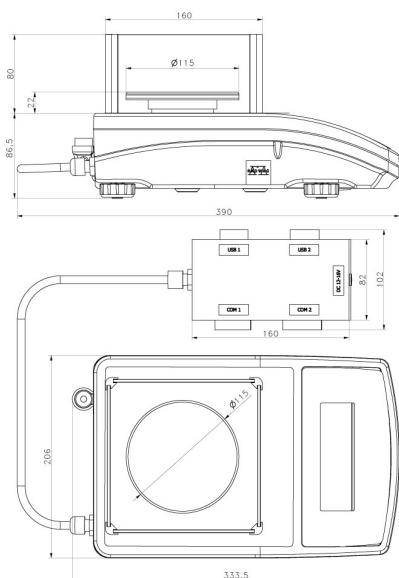

PS R2.H, d = 1 mg

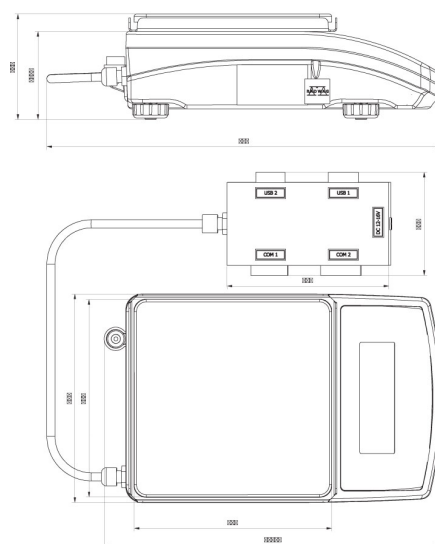

PS R2.M.H, d = 10 mg