



More information on the website  
[radwag.com/en/info,w1,BYZ](http://radwag.com/en/info,w1,BYZ)

# PUE 5.15IR Weighing Terminal



The drawings, photos and graphics used are for illustrative purposes only.

## Functions



Dosing



Labelling



Plus/Minus Control



Parts counting



Formulation



Statistics



Checkweighing

## Datasheet

Metrological parameters	
OIML Class	III
Maximum quantity of divisions from converter	8388608
Maximum quantity of verification units	6000 e
Minimum voltage per verification unit	0.4 $\mu$ V
Maximum voltage per verification unit	3.25 $\mu$ V
Minimum load cell impedance	80 $\Omega$
Maximum load cell impedance	1200 $\Omega$
Load cell excitation voltage	5V
Maximum increase of signal	19.5 mV

<b>Metrological parameters</b>	
Connection of load cells	4 or 6 przewodów
<b>Physical parameters</b>	
Display	15.6" graphic colour touchscreen
Device dimensions	490×310×200 mm
Packaging dimensions	560×360×240 mm
Net weight	10.5 kg
Gross weight	11.5 kg
<b>Construction</b>	
Protection class	IP 67
Touch panel	infrared
Housing	Stainless steel
<b>Communication interface</b>	
Communication interface	4×USB 2.0 (2×USB-A, 2×M12 4P), Ethernet - 2×10/100/1000 Mbit (2×RJ45 hermetic), 2×RS232, RS485 (2×M12 8P)
Optional interfaces	external buttons PRINT, TARE, START - terminal with 4IN/4OUT (M12 8P connector) is required, additional weighing platform module - max. 3 pcs, metrological parameters as in the main weighing platform
<b>Electrical parameters</b>	
Power supply	100 – 240 V AC 50/60 Hz
Power consumption max.	75 W
<b>Environmental conditions</b>	
Operating temperature	0 ÷ +40 °C
Storage temperature	-20 ÷ +60 °C
Relative humidity	10% ÷ 85% RH no condensation
<b>Components and software</b>	
Operating system	Microsoft Windows 11
Processor	Intel® Celeron® J6412
Chipset	Intel® UHD Graphics for 10th Gen Intel® Processors
Memory	16 GB RAM
Data memory	SSD 128 GB



## Compatible with

Waterproof stainless steel platforms  
Mild steel powder coated weighing platforms  
Waterproof stainless steel platforms  
RS 232 cables (scale - printer)  
RS 232 cables (scale - ZEBRA printer)  
RS 232 cables (scale - Ethernet)  
Stainless steel platforms, pit version  
RS 232, RS 485 cables  
Mild steel powder coated weighing platforms  
Ramp stainless steel platforms

IN/OUT Cables  
Barcode scanners  
Stainless steel ramp platforms with LD lifting system  
Label Printers  
Additional Weighing platforms Module  
Keypad, external switches  
USB adapter  
F1 Mass Standard - knob weights without adjustment chamber, set  
USB cable (scale - printer)  
RS 232 – USB Converter

## Software

- RAD Key [WX-010-0005]
- R-Lab [WX-010-0080]

- Label Editor R02 [WX-010-0094]

## Device dimensions

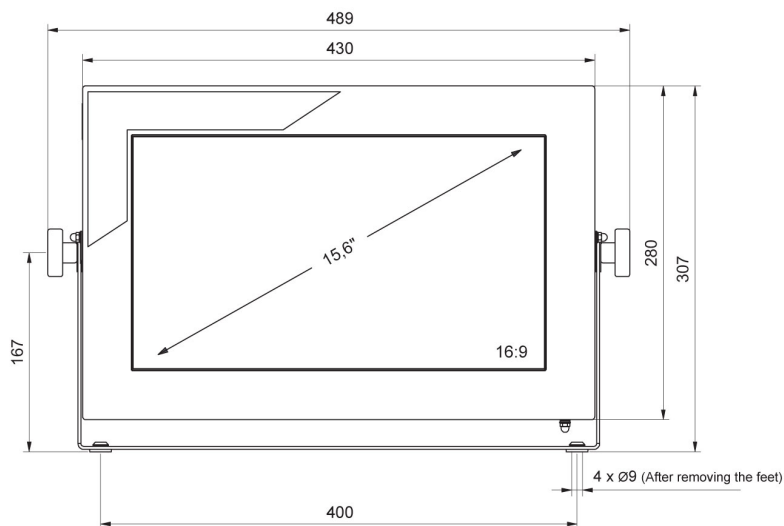
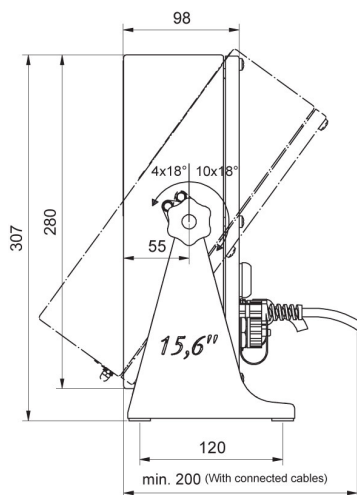

PUE 5.15

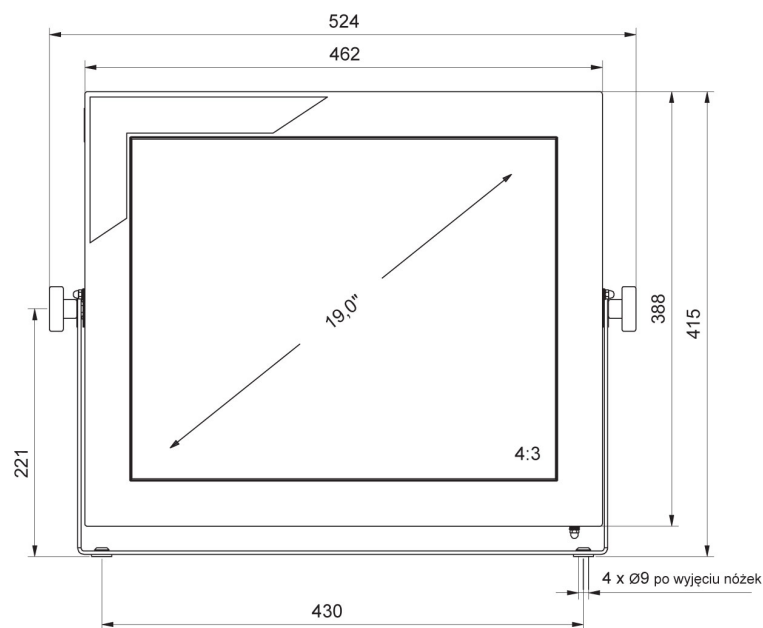
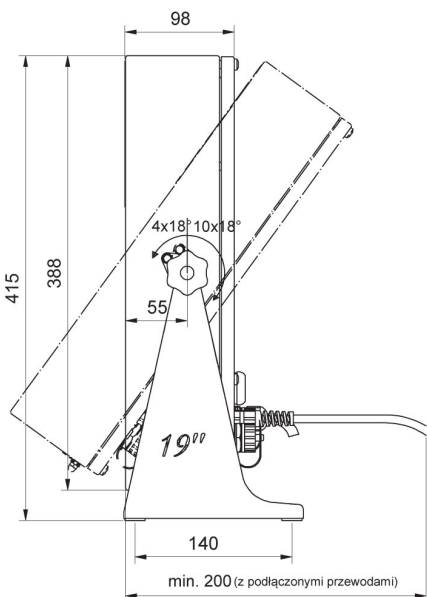

PUE 5.19