

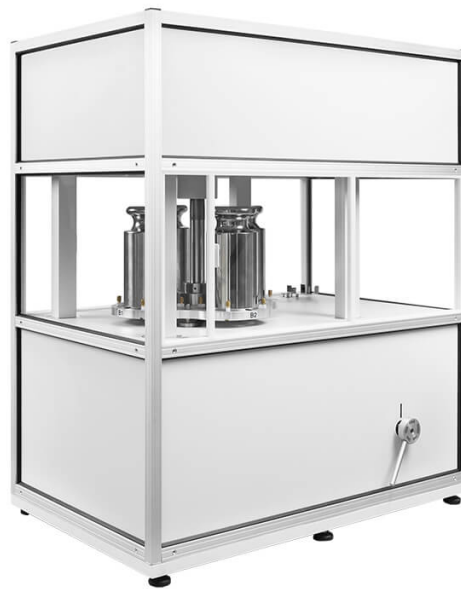

More information on the website  
[radwag.com/us/info,w1,BFH](http://radwag.com/us/info,w1,BFH)

# AK-4.10000.5Y Automatic Mass Comparators



The drawings, photos and graphics used are for illustrative purposes only.

## Datasheet

E1	500 g ÷ 10 kg
E2	500 g ÷ 10 kg
F1	500 g ÷ 10 kg
F2	500 g ÷ 10 kg
Maximum capacity [Max]	10,05 kg
Readability [d]	0,01 mg
Standard repeatability [5% Max]	15 µg
Standard repeatability [Max]	20 µg
Permissible repeatability	40 µg
Eccentricity (tested load)	0 mg
Electric compensation range	-10 g ÷ +50 g
Stabilization time	30 s
Adjustment	external
<b>Physical parameters</b>	
Display	10" graphic colour touchscreen

Physical parameters	
Weighing pan dimensions	ø100 mm
Weighing device dimensions	800×500×930 mm
Controlling device dimensions	249×170×72 mm
Packaging dimensions	1000×900×685 mm
Chamber packaging size	1100×800×1150 mm
Net weight	91 kg
Gross weight	141 kg
Supplementary weights internal	half automatic
Supplementary weights external	-
Communication interface	2×USB-A, USB-C, HDMI, Ethernet, Wi-Fi, Hotspot
Power supply	100 – 240 V AC 50/60 Hz
Operating temperature	+15 ÷ +30 °C
Operating temperature change rate	±0,5°C/12h (±0,3°C/4h)
Relative humidity	40% ÷ 60%
Relative humidity change rate	±5%/12h (3%/4h)

\* Wi-Fi® is a registered trademark of Wi-Fi® Alliance.



## Accessories

RFID Tags  
 Antivibration tables  
 Additional modules  
 Protective cover for balances  
 Barcode scanners  
 RS 232, RS 485 cables

THBR 2.0 System - Ambient Conditions Monitoring  
 Receipt Printer  
 Fingerprint Reader  
 RS 232, RS 485 cables  
 RS 232 cables (scale - printer)

## Software

• RAD Key [WX-010-0005]  
 • RMCS System Network Management of Calibration Process [WX-010-0048]

• RMCS Lite [WX-010-0164]

## Device dimensions

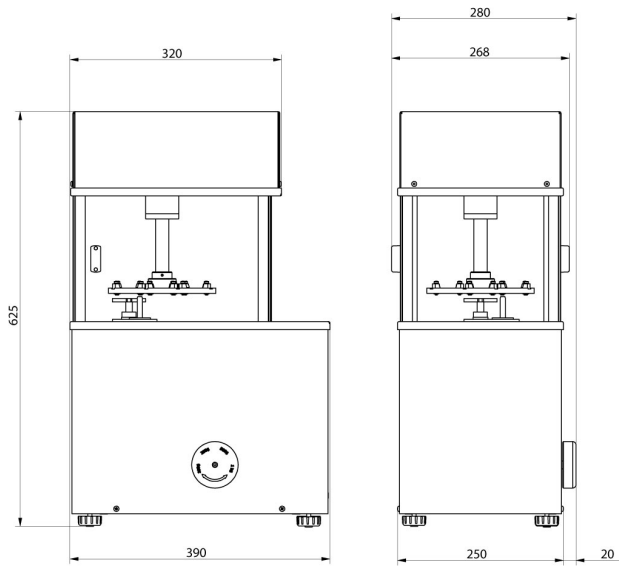

AK-4/100, AK-4/1000,  
AK-4/1000.1

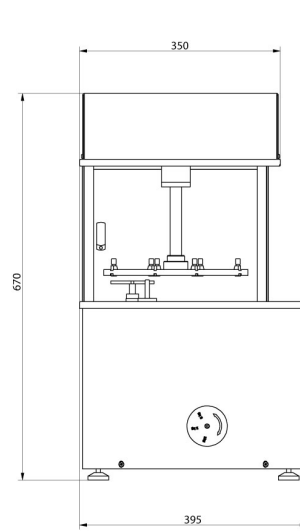

AK-4/2000, AK-4/5000,  
AK-4/5000.1

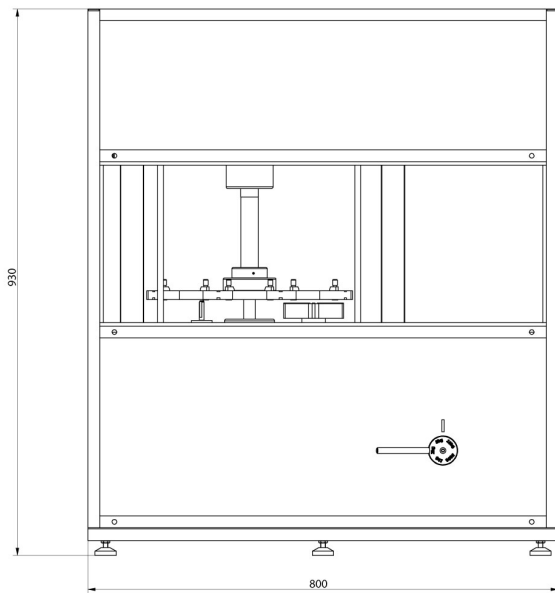
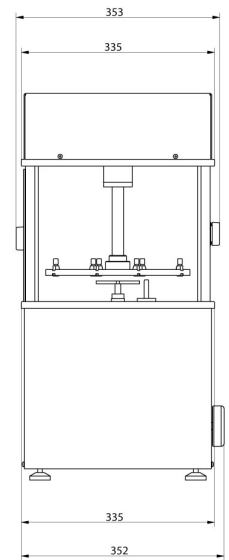

AK-4/10000, AK-4/16000

