



More information on the website
radwag.com/en/info,w1,APQ

AS 310.R2 PLUS Analytical Balance



The drawings, photos and graphics used are for illustrative purposes only.

Functions



Autotest



Dosing



Percent Weighing



Totalizing



Parts counting



Peak hold



Newton unit measurement



Statistics



Checkweighing



Under-pan weighing



GLP Procedures



Animal weighing



Density determination

Datasheet

Metrological parameters	
Maximum capacity [Max]	310 g
Minimum load	10 mg
Readability [d]	0.1 mg
Verification unit [e]	1 mg
Tare range	-310 g
Standard repeatability [5% Max]	0.08 mg

Metrological parameters	
Standard repeatability [Max]	0.12 mg
Standard minimum weight (USP)	160 mg
Standard minimum weight (U=1%, k=2)	16 mg
Permissible repeatability [5% Max]	0.12 mg
Permissible repeatability [Max]	0.15 mg
Linearity	±0.3 mg
Stabilization time	2.5 s
Adjustment	internal (automatic)
OIML Class	I
Physical parameters	
Leveling system	manualny
Display	LCD (backlit)
Weighing chamber doors	manual
Delivery components	Balance, weighing pan, weighing pan shield, bottom cover, power supply.
Weighing pan dimensions	ø100 mm
Packaging dimensions	490×400×520 mm
Net weight	7.01 kg
Gross weight	9 kg
Construction	
Protection class	IP 43
Communication interface	
Communication interface	2×RS232 ¹ , 2×USB-A (interchangeable), USB-B, Wi-Fi (option)
Electrical parameters	
Power supply	Adapter: 100 – 240V AC 50/60Hz 0.6A; 12V DC 1.2A Balance: 12 – 15V DC 0.4A max
Power consumption max.	3 W
Environmental conditions	
Operating temperature	+10 ÷ +40 °C
Relative humidity	40% ÷ 80%

Repeatability is expressed as a standard deviation from 10 weighing cycles.

Stabilization time depends on the ambient conditions and the dynamics of weighing pan loading; specified for FAST profile.

¹ Barcode scanners, available as weighing instrument accessory, communicate with the instrument via RS232 interface exclusively.

* Wi-Fi® is a registered trademark of Wi-Fi® Alliance.



Extra payment for verification



Accessories

Antivibration Tables
 Holders for laboratory flasks
 Power Adapters

RS 232, RS 485 cables
 Displays
 Protective cover for balances

Cigarette lighter receptacle power supply cables
 Density determination KIT
 USB cable (scale - printer)
 Professional Weighing Tables
 Barcode scanners
 Holders for test tubes and filters
 Workstation for Pipettes Calibration

Weighing dishes
 Antistatic ionizer
 Receipt Printer
 RS 232, RS 485 cables
 Under-pan weighing
 RS 232 cables (scale - printer)

Software

- RAD Key [WX-010-0005]
- Alibi Reader [WX-010-0114]
- RADWAG Development Studio [WX-010-0104]
- R-Panel [WX-010-0187]
- R-Lab [WX-010-0080]

Device dimensions

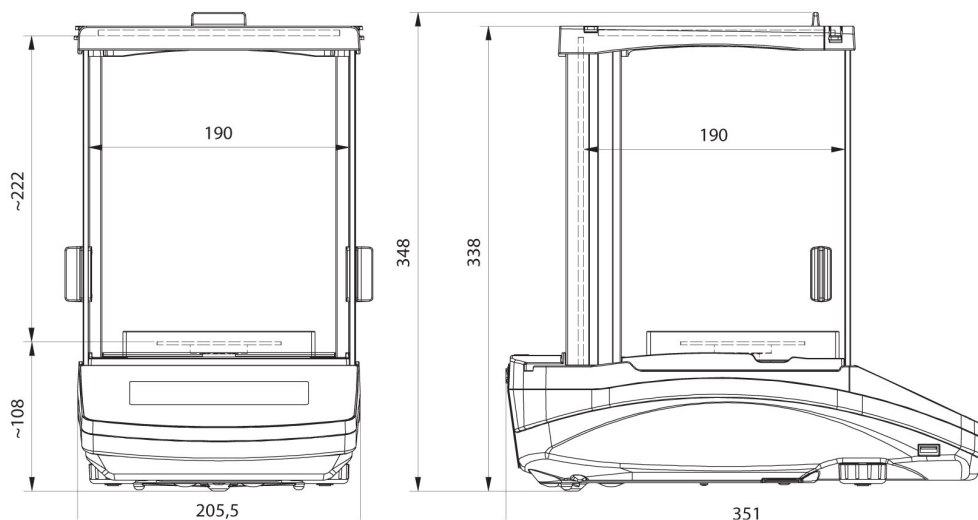

AS R2, d = 0.01 mg

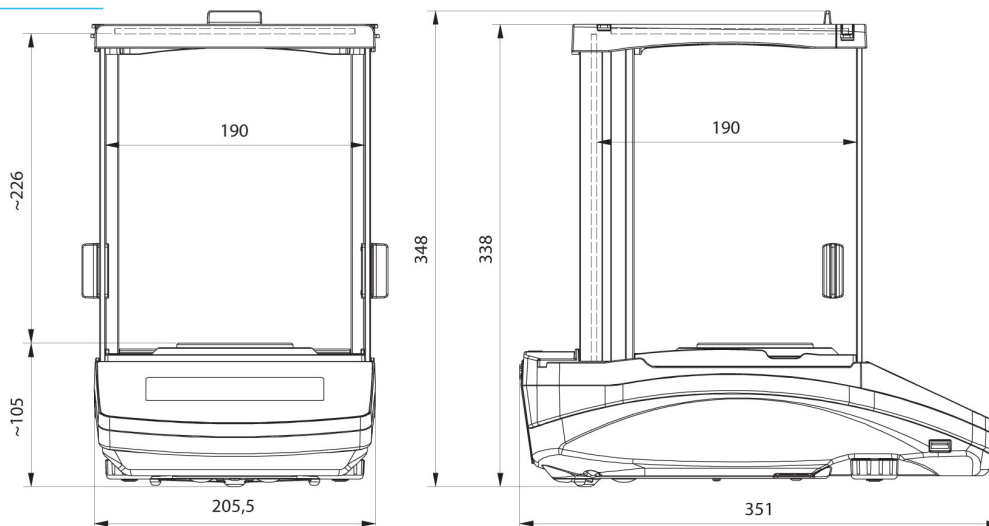

AS R2, AS R1 d = 0.1 mg