



More information on the website
radwag.com/it/info,w1,9HA

Sistemi di pesatura animali H315.4I.2000.S1



The drawings, photos and graphics used are for illustrative purposes only.

Funzioni



Plus/Minus Control



Percent Weighing



Totalizing



Parts counting



Internal battery



Peak hold



Newton unit
measurement



Animal weighing

Specifiche

Parametri metrologici

Portata massima [Max]	2000 kg
Portata minima [Min]	20 kg
Divisione [d]	1 kg
Campo di tara	-2000 kg
Classe OIML	III

Parametri fisici

Display	LCD (backlit)
Lunghezza del cavo	3 m
Dimensione piatto	1×2 m

Parametri fisici	
Mass scala con indicatore	290 kg
Altezza delle barriere	1,1 m
Costruzione	
Punteggio IP	IP 67 construction, IP 68 (1h max)/69 terminal
Interfaccia di comunicazione	
Interfaccia	RS232, USB
Interfacce opzionali	RS232 or RS485 or 4IN/4OUT or Ethernet or analog output 4-20 mA
Parametri elettrici	
Alimentatore	100 – 240 V AC 50/60 Hz
Alimentatore opzionale	internal rechargeable battery
Tempo operativo delle batterie	max 7h
Environmental conditions	
Ambiente di lavoro	-10 – +40 °C
Umidità relativa	10% – 85% RH no condensation



Extra payment for verification



Accessori

Cavo seriale RS 232 (connessione bilance - Stampanti)
 Display
 Cavo seriale RS 232 (connessione bilance - Ethernet)
 Cavo seriale RS 232, RS 485
 RS 232 – Ethernet Converter
 USB adatper

Stampanti di ricevuta
 cavo USB (connessione bilance - stampanti)
 Supporto, set di montaggio a muro e braccetti di montaggio
 RS 232 – USB Converter
 Cavo seriale RS 232, RS 485

Software

- RAD Key [WX-010-0005]
- R-LAB [WX-010-0080]

- R Panel [WX-010-0187]
- Editore per sistemi di pesatura 2.1 [WX-010-0173]

Device dimensions

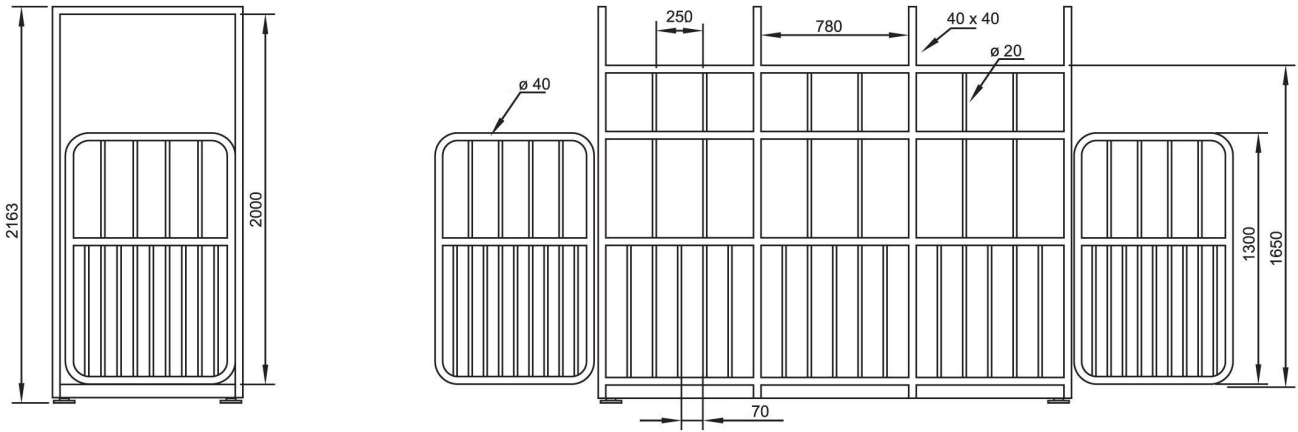

Option of door customization
 (opening direction and type due
 to different combinations of hinges
 assembling and various door models)

