

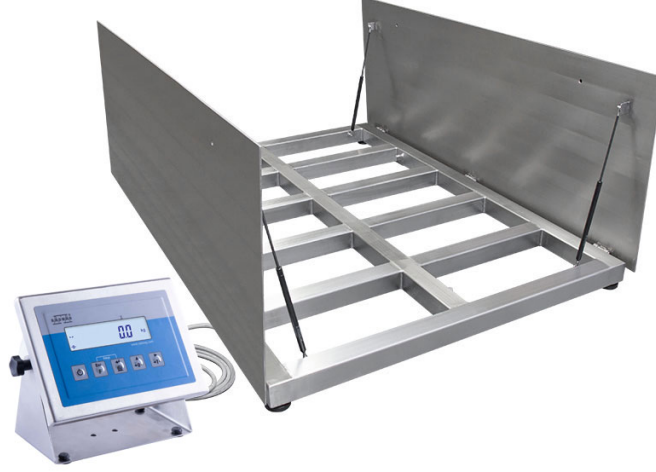

H315.4.1500.H8/9/Z Paslanmaz Çelik Yer Kantarı, Zemin İçi



The drawings, photos and graphics used are for illustrative purposes only.

Fonksiyonlar



Plus/Minus Control



Percent Weighing



Totalizing



Parts counting



Internal battery



Peak hold



Newton unit measurement



Animal weighing

Teknik Veriler

Metrolojik parametreler	
Maksimum yük [Max]	1500 kg
Minimum yük [Min]	10 kg
Okuma için doğruluğu [d]	500 g
Dara aralığı	-1500 kg
Ticari amaçla kullanılmayan terazi için maksimum hassasiyet	100 g
OIML sınıfı	III
Fiziksel parametreler	
Display	LCD (aydınlatma ile)
Kablo uzunluğu	3 m

Fiziksel parametreler

Tartım kefesi boyutları	1200×1500 mm
Tartım platformunun yüksekliği	88 mm
Ambalaj boyutları	1700×1400×550 mm
Göstergeli ve çerçevesiz terazi kütlesi	178 kg

Konstrüksiyon

IP Sınıfı	IP 68 konstrüksiyon, IP 68 (1h max)/69 terminal
-----------	---

Haberleşme arayüzler

Haberleşme arayüzü	RS232, USB
Opsiyonel arayüzler	RS232 veya RS485 veya 4IN/4OUT veya Ethernet veya analog çıkış 4-20 mA

Elektrik parametreleri

Güç kaynağı	100 – 240 V AC 50/60 Hz
Opsiyonel güç kaynağı	dahili batarya
Batarya ile çalışma süresi	max 7h

Çevresel koşullar

Çalıştırma sıcaklığı	-10 – +40 °C
Atmosferik nem	10% – 85% RH yoğunlaşma yok



Extra payment for verification



Aksesuarlar

RS 232 cables (scale - printer)
Display
RS 232 cables (scale - Ethernet)
RS 232, RS 485 cables
RS 232 – Ethernet Converter
USB adaptör

Fiş yazıcı
USB kablo (terazi-Epson yazıcı)
Tartım terminalleri için tutucular
RS 232 – USB Converter
RS 232, RS 485 Kabloları

Yazılım

• RAD Key [WX-010-0005]
• R-Lab [WX-010-0080]

• R Panel [WX-010-0187]
• Terazi Editörü - EWAG 2.1 [WX-010-0173]

Cihaz boyutları

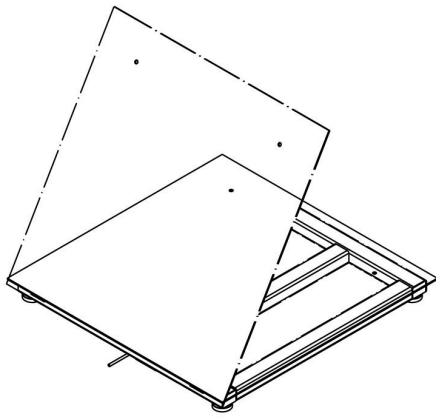

Single-leaf platform:

H315.4.H6/Z

H315.4.H7/Z

H315.4.H8/Z

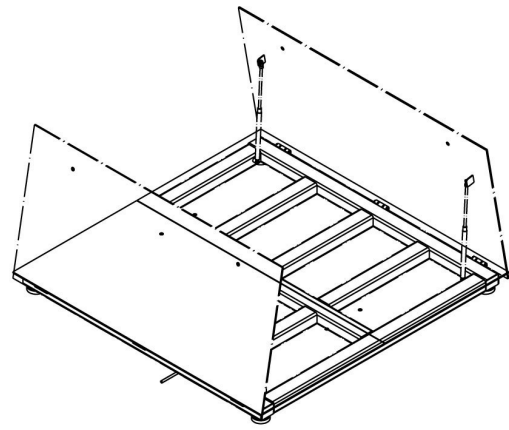

Double-leaf platform:

H315.4.H8/9/Z

H315.4.H9/Z

H315.4.H10/Z

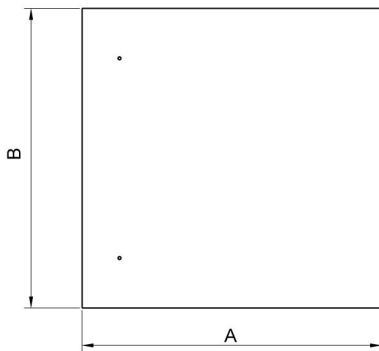
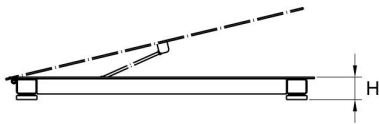

Scale type	A	B	H
H315.4.150-600.H6/Z	800	800	88±2
H315.4.150-1500.H7/Z	1000	1000	88±2
H315.4.300-1500.H8/Z	1200	1200	88 ±2
H315.4.3000.H8/Z	1200	1200	111 ±2
H315.4.300-1500.H8/9/Z	1200	1500	88 ±2
H315.4.3000.H8/9/Z	1200	1500	111 ±2
H315.4.300-1500.H9/Z	1500	1500	88 ±2
H315.4.3000-6000.H9/Z	1500	1500	111 ±2
H315.4.600-6000.H10/Z	1500	2000	111 ±2

dimensions in mm