



More information on the website  
[radwag.com/en/info,w1,8P3](http://radwag.com/en/info,w1,8P3)

# PS 2100.R2.M.H Precision Balance



The drawings, photos and graphics used are for illustrative purposes only.

## Functions

-  Autotest
-  Dosing
-  Percent Weighing
-  Totalizing
-  Parts counting
-  Peak hold
-  Newton unit measurement
-  Statistics
-  Checkweighing
-  Under-pan weighing
-  GLP Procedures
-  Animal weighing
-  Density determination

## Datasheet

Metrological parameters	
Maximum capacity [Max]	2100 g
Minimum load	500 mg
Readability [d]	0.01 g
Tare range	-2100 g
Standard minimum weight (USP)	10 g
Standard minimum weight (U=1%, k=2)	1 g

<b>Metrological parameters</b>	
Repeatability (Max)	0.008 g
Repeatability (5% Max)	0.005 g
Linearity	±0.02 g
Stabilization time	1.5 s
Adjustment	internal (automatic)
Sensitivity temperature drift	$2 \times 10^{-6} / ^\circ\text{C} \times \text{Rt}$
<b>Physical parameters</b>	
Leveling system	manual
Display	LCD (backlit)
Delivery components	Balance, weighing pan, weighing pan shield, power supply
Weighing pan dimensions	195×195 mm
Packaging dimensions	475×380×345 mm
Net weight	3.6 kg
Gross weight	5.1 kg
<b>Construction</b>	
Protection class	IP 54
<b>Communication interface</b>	
Communication interface	2×RS232 <sup>1</sup> , USB-A, USB-B, Wi-Fi (option)
<b>Electrical parameters</b>	
Power supply	Adapter: 100 – 240V AC 50/60Hz 0.6A; 12V DC 1.2A Balance: 12 – 15V DC 0.4A max
Power consumption	4 W
<b>Environmental conditions</b>	
Operating temperature	+10 ÷ +40 °C
Relative humidity	40% ÷ 80%

Repeatability is expressed as a standard deviation from 10 weighing cycles.

Stabilization time depends on the ambient conditions and the dynamics of weighing pan loading; specified for FAST profile.

<sup>1</sup> Barcode scanners, available as weighing instrument accessory, communicate with the instrument via RS232 interface exclusively.

\* Wi-Fi® is a registered trademark of Wi-Fi® Alliance.



## Accessories

Antivibration Tables  
Power Adapters  
Cigarette lighter receptacle power supply cables  
USB cable (scale - printer)  
Barcode scanners  
RS 232, RS 485 cables

Displays  
Receipt Printer  
RS 232, RS 485 cables  
Protective cover for balances  
Under-pan weighing  
RS 232 cables (scale - printer)

## Software

- RAD Key [WX-010-0005]
- Alibi Reader [WX-010-0114]
- RADWAG Development Studio [WX-010-0104]

- R-Panel [WX-010-0187]
- R-Lab [WX-010-0080]

## Device dimensions

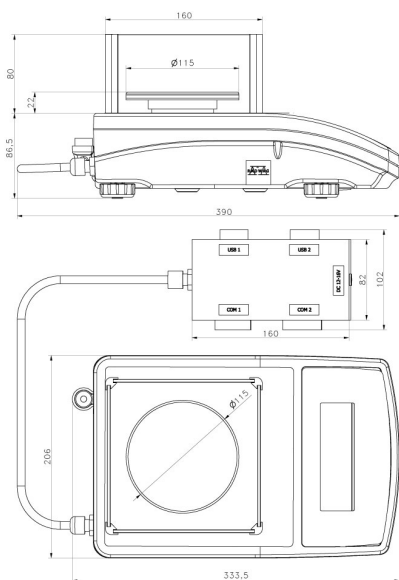

PS R2.H, d = 1 mg

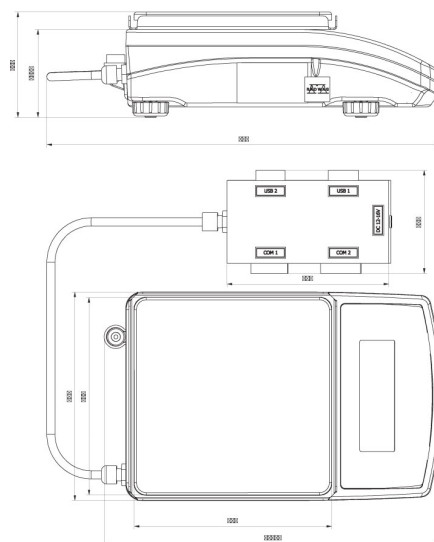

PS R2.M.H, d = 10 mg