



More information on the website
radwag.com/us/info,w1,821

AGV-8 1000.5Y Automatic Comparator for determination of mass standard's density and volume



The drawings, photos and graphics used are for illustrative purposes only.

Datasheet

E1	1 g ÷ 1 kg
Maximum capacity [Max]	1110 g
Readability [d]	0,01 mg
Standard repeatability [5% Max]	0,04 mg
Standard repeatability [Max]	0,05 mg
Permissible repeatability	0,08 mg
Electric compensation range	-10 g ÷ +110 g
Stabilization time	30 s
Adjustment	external
Physical parameters	
Display	10" graphic colour touchscreen
Magazine positions	8
Weighing pan dimensions	ø60 mm
Object diameters	5-94 mm
Weighing device dimensions	690×710×1060 mm

Supplementary weights external	500 g, 300 g, 100 g, 100 g
Power supply	100 – 240 V AC 50/60 Hz
Operating temperature	+15 ÷ +30 °C
Storage temperature	-20 ÷ +50 °C
Operating temperature change rate	±0,5°C/12h (±0,3°C/4h)
Relative humidity	40% ÷ 60%
Relative humidity change rate	±5%/12h (3%/4h)



Accessories

RFID Tags
 Antivibration tables
 Additional modules
 Protective cover for balances
 Barcode scanners
 RS 232, RS 485 cables

THBR 2.0 System - Ambient Conditions Monitoring
 Receipt Printer
 Fingerprint Reader
 RS 232, RS 485 cables
 RS 232 cables (scale - printer)

Software

• RMCS Lite [WX-010-0164]

• RMCS System Network Management of Calibration Process [WX-010-0048]

Device dimensions

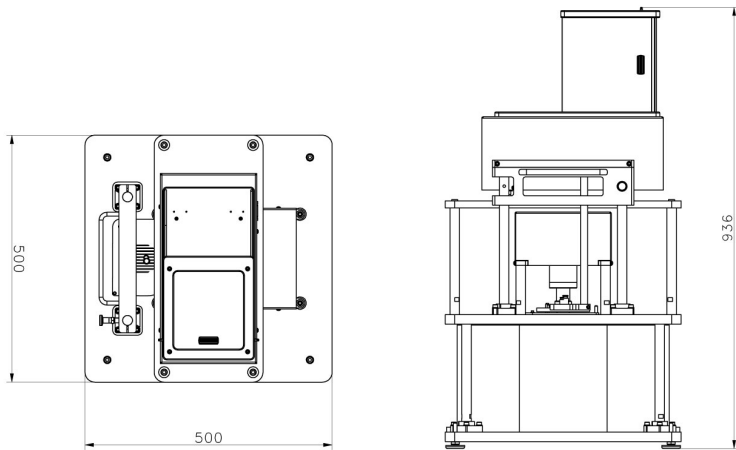

AGV-8/1000

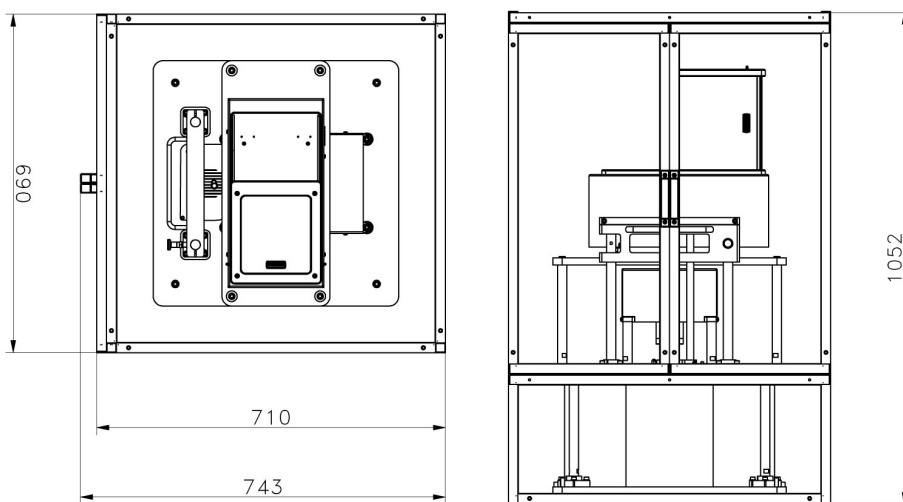

AGV-8/1000
Anti-draft chamber ver.1

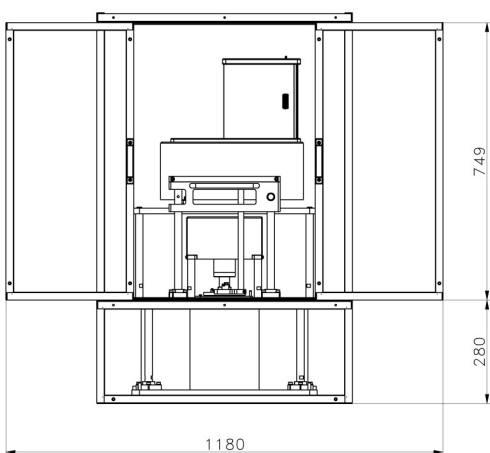

AGV-8/1000
Anti-draft chamber ver.2