



More information on the website
radwag.com/it/info,w1,7C5

Bilancia di precisione PS 200/2000.R2.H



The drawings, photos and graphics used are for illustrative purposes only.

funzioni



Autotest



Dosing



Percent Weighing



Totalizing



Parts counting



Peak hold



Newton unit measurement



Statistics



Checkweighing



GLP Procedures



Animal weighing



Density determination

Foglio di calcolo

Parametri metrologici	
Capacità massima [Max]	200 / 2000 g
Pesata minima	20 mg
Accuratezza	0,001 / 0,01 g
Intervallo di tara	-2000 g
Ripetibilità (Max)	0,001 / 0,01 g
Ripetibilità (5% Max)	0,0005 / 0,005 g
Linearità	±0,002 / 0,02 g

Parametri metrologici	
Tempo di stabilizzazione	2 / 1,5 s
Calibrazione	internal (automatic)
Sensibilità di variazione della temperatura	$2 \times 10^{-6} / ^\circ\text{C} \times \text{Rt}$
Parametri fisici	
Sistema di livellamento	manualny
Display	LCD (backlit)
Dimensioni del piatto di pesata	$\varnothing 100 \text{ mm}$
Dimensioni del pacco	475x380x345 mm
Peso netto	4,5 kg
Peso lordo	6,5 kg
Costruzione	
Punteggio IP	IP 54
Interfaccia di comunicazione	
Interfaccia	2xRS232 ¹ , USB-A, USB-B, Wi-Fi (option)
Parametri elettrici	
Alimentatore	Adapter: 100 – 240V AC 50/60Hz 0,6A; 12V DC 1,2A Balance: 12 – 15V DC 0,4A max
Consumo di energia	4 W
Environmental conditions	
Temperatura di lavoro	+10 ÷ +40 °C
Umidità atmosferica	40% ÷ 80%

* Wi-Fi® is a registered trademark of Wi-Fi® Alliance.



Accessori

Tavoli antivibranti

Alimentatore

Cavo di alimentazione con spina per accendisigari

cavo USB (connessione bilance - stampanti)

Lettoce di codici a barre

Cavo seriale RS 232, RS 485

Display

Stampanti di ricevuca

Cavo seriale RS 232, RS 485

Capottina protettiva per bilance

Under-pan weighing

Cavo seriale RS 232 (connessione bilance - Stampanti)

Software

• RAD Key [WX-010-0005]

• „Alibi Reader” PC Software [WX-010-0114]

• Software „Development Studio” RADWAG [WX-010-0104]

• R Panel [WX-010-0187]

• R-LAB [WX-010-0080]

Device dimensions



PS R2.H, d = 1 mg

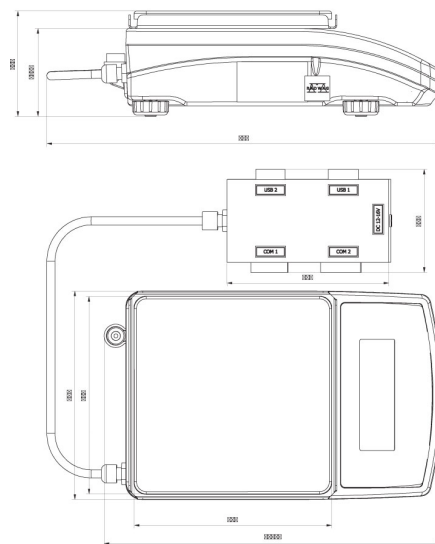

PS R2.M.H, d = 10 mg