



H315.2K.300/600 Asma ray kantarı



The drawings, photos and graphics used are for illustrative purposes only.

Fonksiyonlar



Plus/Minus Control



Percent Weighing



Totalizing



Parts counting



Internal battery



Peak hold



Newton unit
measurement



Animal weighing

Teknik Veriler

Metrolojik parametreler	
Maksimum yük [Max]	300 / 600 kg
Minimum yük [Min]	2 kg
Okuma up doğruluğu [d]	0,1 / 0,2 kg
Dara aralığı	-600 kg
OIML sınıfı	III
Fiziksel parametreler	
Display	LCD (backlit)
Algılama hattı genişliği	L= 800 mm (min. 200 mm)

Konstrüksiyon

IP Sınıfı IP 67 construction, IP 68 (1h max)/69 indicator

Konstrüksiyon galvanized

Haberleşme arayüzler

Haberleşme arayüzü RS232, USB

Opsiyonel arayüzler RS232 or RS485 or 4IN/4OUT or Ethernet or analog output 4-20 mA

Elektrik parametreleri

Güç kaynağı 100 – 240 V AC 50/60 Hz

Opsiyonel güç kaynağı internal rechargeable battery

Batarya ile çalışma süresi max 7h

Çevresel koşullar

Çalıştırma sıcaklığı -10 ÷ +40 °C

Atmosferik nem 10% ÷ 85% RH no condensation



Extra payment for verification



Aksesuarlar

RS 232 cables (scale - printer)
Display
RS 232 cables (scale - Ethernet)
RS 232, RS 485 cables
RS 232 – Ethernet Converter
USB adaptör

Fiş yazıcı
USB kablo (terazi-Epson yazıcı)
Tartım terminalleri için tutucular
RS 232 – USB Converter
RS 232, RS 485 Kabloları

Yazılım

• RAD Key [WX-010-0005]
• R-Lab [WX-010-0080]

• R Panel [WX-010-0187]
• Terazi Editörü - EWAG 2.1 [WX-010-0173]

Cihaz boyutları



CAUTION

- Standard version of the weighing track length: $L = 800$ mm
- The truck in the place of assembling the scale has to be horizontal with a ± 10 mm tilt limit
- The dimensions bearing the letters are to be agreed with contractor manufacturing Z dimension; the dimensions can be omitted if the following relation is fulfilled: $Z \leq 80\% D$

Dimensions of an overhead track scale with a shaft of $\varnothing 60$ (standard version)

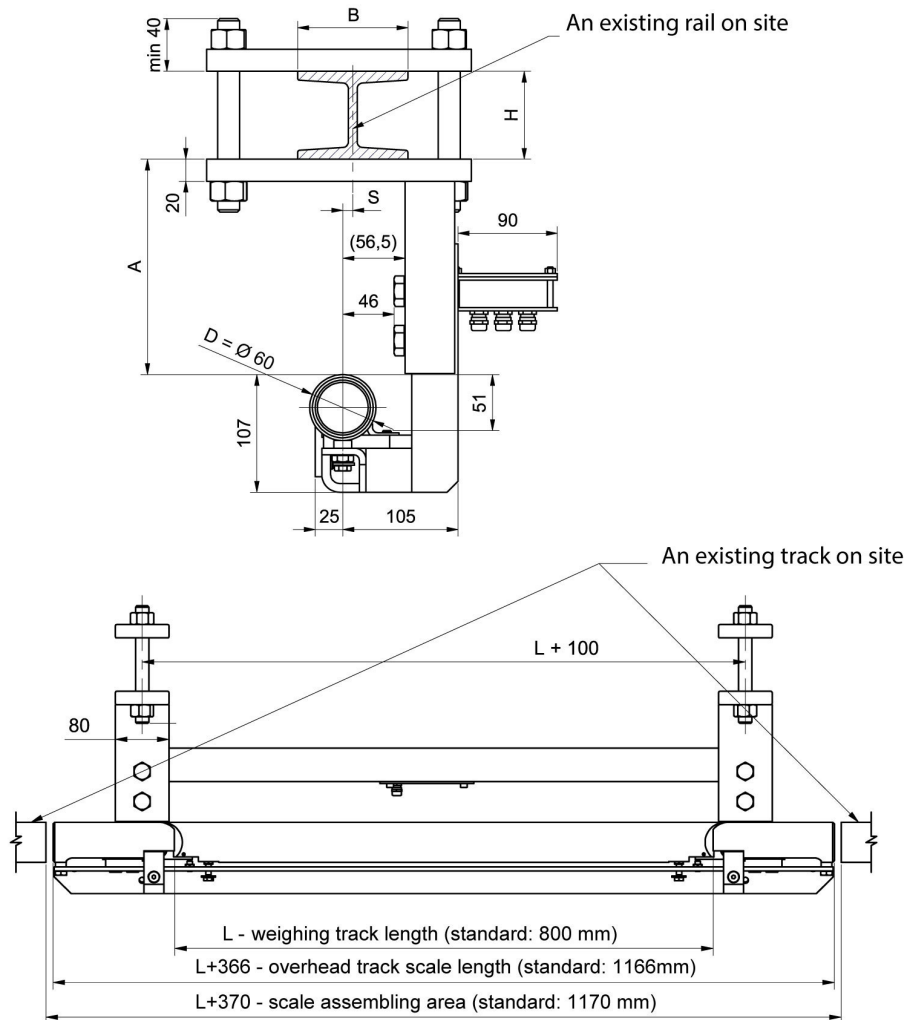

Minimum track clearance: $A = 90$ mm.
 Weighing track length: $200 \leq L \leq 800$ mm. As a standard: $L=800$ mm.
 Maximum capacity: 600 kg.