



More information on the website  
radwag.com/en/info,w1,3YL

# PS 8100.R2.M Precision Balance



The drawings, photos and graphics used are for illustrative purposes only.

## Functions



Autotest



Dosing



Percent Weighing



Totalizing



Parts counting



Peak hold



Newton unit measurement



Statistics



Checkweighing



Under-pan weighing



GLP Procedures



Animal weighing



Density determination

## Datasheet

Metrological parameters	
Maximum capacity [Max]	8100 g
Minimum load	500 mg
Readability [d]	10 mg
Verification unit [e]	100 mg
Tare range	-8100 g
Standard repeatability [5% Max]	5 mg

Metrological parameters	
Standard repeatability [Max]	10 mg
Standard minimum weight (USP)	10 g
Standard minimum weight (U=1%, k=2)	1 g
Linearity	±20 mg
Stabilization time	1.5 s
Adjustment	internal (automatic)
OIML Class	II
Sensitivity temperature drift	$2 \times 10^{-6} / ^\circ\text{C} \times \text{Rt}$
Physical parameters	
Leveling system	manual
Display	LCD (backlit)
Delivery components	Balance, weighing pan, weighing pan shield, power supply
Weighing pan dimensions	195×195 mm
Device dimensions	333×206×107 mm
Packaging dimensions	475×380×345 mm
Net weight	4.5 kg
Gross weight	7.5 kg
Construction	
Protection class	IP 43
Communication interface	
Communication interface	2×RS232 <sup>1</sup> , USB-A, USB-B, Wi-Fi (option)
Electrical parameters	
Power supply	Adapter: 100 – 240V AC 50/60Hz 0.6A; 12V DC 1.2A Balance: 12 – 15V DC 0.4A max
Power consumption	4 W
Environmental conditions	
Operating temperature	+10 – +40 °C
Storage temperature	-20 – +50 °C
Relative humidity	40% – 80%

**Repeatability** is expressed as a standard deviation from 10 weighing cycles.

**Stabilization time** depends on the ambient conditions and the dynamics of weighing pan loading; specified for FAST profile.

<sup>1</sup> Barcode scanners, available as weighing instrument accessory, communicate with the instrument via RS232 interface exclusively.

\* Wi-Fi® is a registered trademark of Wi-Fi® Alliance.



Additional fee for verification



## Accessories (Additional Fee)

Balance Storage Case  
Antivibration Tables  
Power Adapters  
Cigarette lighter receptacle power supply cables

Displays  
Density determination KIT  
Protective cover for balances  
Receipt Printer

USB cable (scale - printer)  
Barcode scanners  
RS 232, RS 485 cables

RS 232, RS 485 cables  
Under-pan weighing  
RS 232 cables (scale - printer)

## Software (Additional Fee)

- RAD Key [WX-010-0005]
- Alibi Reader [WX-010-0114]
- RADWAG Development Studio [WX-010-0104]
- R-Panel [WX-010-0187]
- R-Lab [WX-010-0080]

## Device dimensions

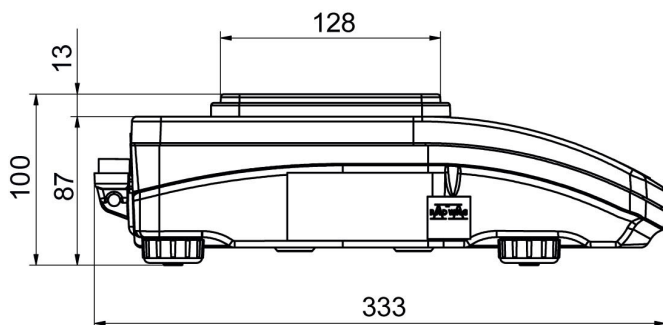

PS R, d = 1mg

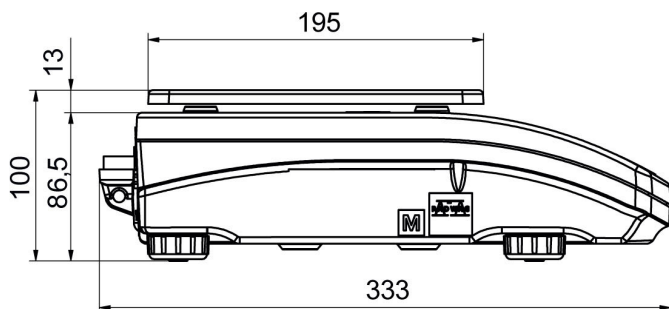
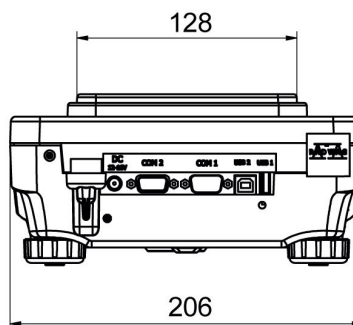

PS R, d = 10 mg

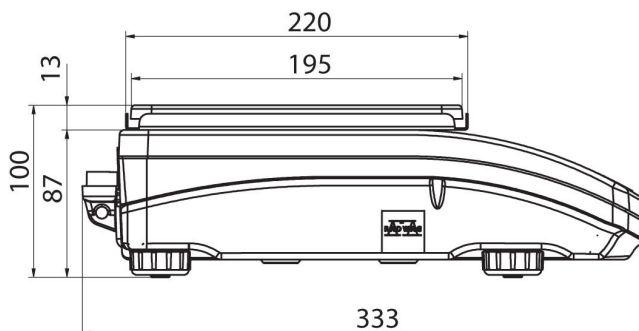
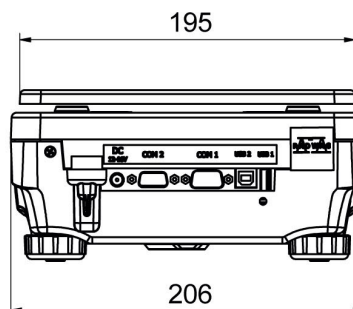

PS R.M, d = 10 mg

