



More information on the website
radwag.com/us/info,w1,303

WAY 2.5Y.KO Mass Comparator



The drawings, photos and graphics used are for illustrative purposes only.

Datasheet

| | |
|---------------------------------|----------------|
| E1 | 1 kg ÷ 2 kg |
| E2 | 500 g ÷ 2 kg |
| F1 | 100 g ÷ 2 kg |
| F2 | 10 g ÷ 2 kg |
| M1 | 1 g ÷ 2 kg |
| M2 | 1 g ÷ 2 kg |
| Maximum capacity [Max] | 2,3 kg |
| Readability [d] | 0,1 mg |
| Standard repeatability [5% Max] | 0,08 mg |
| Standard repeatability [Max] | 0,1 mg |
| Permissible repeatability | 0,2 mg |
| Eccentricity (tested load) | 0 mg* |
| Electric compensation range | -50 g ÷ +300 g |
| Stabilization time | 20 s |
| Adjustment | internal |

| Physical parameters | |
|-----------------------------------|--|
| Display | 10" graphic colour touchscreen |
| Weighing pan dimensions | ø70 mm |
| Weighing device dimensions | 385×215×525 mm |
| Controlling device dimensions | 249×170×72 mm |
| Anti-draft chamber dimensions | 660×470×700 mm |
| Packaging dimensions | 945×820×1260 mm |
| Chamber packaging size | 820×850×630 mm |
| Net weight | 39,5 kg |
| Gross weight | 59,5 kg |
| Supplementary weights internal | automatic |
| Supplementary weights external | 2× 100 g |
| | |
| Communication interface | 2×USB-A, USB-C, HDMI, Ethernet, Wi-Fi, Hotspot |
| | |
| Operating temperature | +15 ÷ +30 °C |
| Operating temperature change rate | ±0,5°C/12h (±0,3°C/4h) |
| Relative humidity | 40% ÷ 60% |
| Relative humidity change rate | ±3%/4h |

* Wi-Fi® is a registered trademark of Wi-Fi® Alliance.



Accessories

| | |
|---|---|
| Suspended Self-Centring Weighing Pan for WAY 5Y.KO Manual Mass Comparator | Label Printers |
| RFID Tags | THBR 2.0 System - Ambient Conditions Monitoring Receipt Printer |
| Antivibration tables | Fingerprint Reader |
| Additional modules | RS 232, RS 485 cables |
| Protective cover for balances | RS 232 cables (scale - printer) |
| Barcode scanners | |
| RS 232, RS 485 cables | |

Software

| | |
|---|---------------------------|
| • RAD Key [WX-010-0005] | • RMCS Lite [WX-010-0164] |
| • RMCS System Network Management of Calibration Process [WX-010-0048] | |

Device dimensions

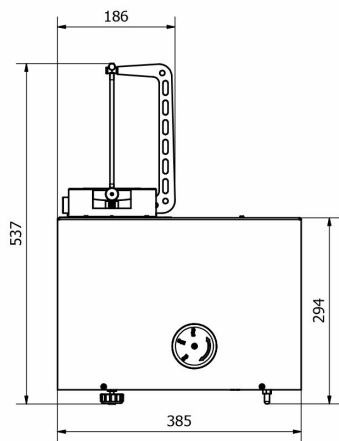

WAY 5.5Y.KO

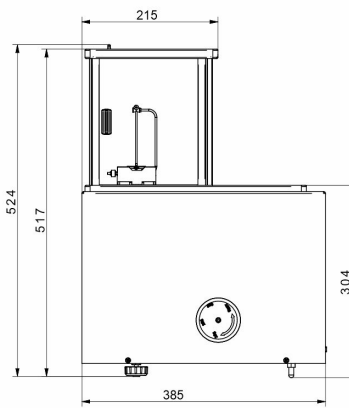
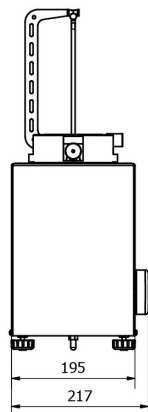

WAY 100.5Y.KO

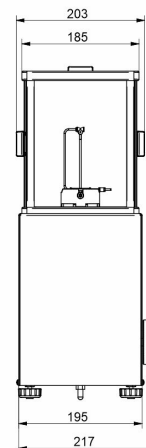

WAY 1200.5Y.KO

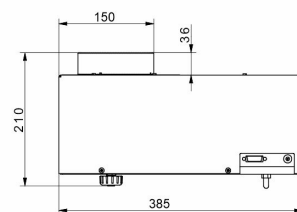

WAY 5100.5Y.KO

