



More information on the website  
radwag.com/it/info,w1,2VV

# HY10.150.1.HRP.M2.2 Basamenti ad alta risoluzione



The drawings, photos and graphics used are for illustrative purposes only.

## Funzioni

-  Dosing
-  Labelling
-  Plus/Minus Control
-  Percent Weighing
-  Totalizing
-  Parts counting
-  Peak hold
-  Formulation
-  Newton unit measurement
-  Statistics
-  Checkweighing
-  GLP Procedures
-  Animal weighing
-  Differential weighing
-  Replaceable unit
-  Statistical Quality Control
-  ALIBI Memory
-  Transactions

## Specifiche

| Parametri metrologici   |        |
|-------------------------|--------|
| Portata massima [Max]   | 150 kg |
| Portata minima [Min]    | 250 g  |
| Intervallo di precarico | 30 kg  |
| Divisione [d]           | 5 g    |

| Parametri metrologici                     |   |
|---|---|
| Intervallo di verifica della bilancia [e] | 5 g   |
| Campo di tara                             | -150 kg   |
| Ripetibilità                              | 1,5 g   |
| Linearità                                 | ±5 g  |
| Tempo di stabilizzazione                  | 3 s   |
| Calibrazione                              | internal (automatic)  |
| Classe OIML                               | II  |
| Quantità massima di unità verificate      | 30000 e   |
| Parametri fisici                          |   |
| Display                                   | 10,1" graphic colour touchscreen  |
| Dimensione piatto                         | 800x600 mm  |
| Dimensioni del pacco                      | 800x1000x537 mm   |
| Peso netto                                | 71,5 kg   |
| Peso lordo                                | 119 kg  |
| Costruzione                               |   |
| Punteggio IP                              | IP 66 / 67 construction, IP 68 / 69 terminal  |
| Costruzione                               | mild steel St3S   |
| Materiale da pesata                       | Stainless steel AISI304   |
| Interfaccia di comunicazione              |   |
| Interfaccia                               | 2xRS232, 2xUSB-A, Ethernet, 4 IN / 4 OUT (digital)  |
| Interfacce opzionali                      | module Wi-Fi 802.11 b/g/n, module Profibus (DP SLAVE), module RS485, module PROFINET (RJ45), analog output module (4-20mA, 0-20mA, 0-10V) , 12IN / 12OUT (IN – 5-24 VDC, OUT – max 30 VDC, 0,5 ADC) |
| Parametri elettrici                       |   |
| Alimentatore                              | 100 – 240 V AC 50/60 Hz   |
| Environmental conditions                  |   |
| Ambiente di lavoro                        | +10 – +40 °C  |
| Umidità relativa                          | 15% – 80%   |

La **ripetibilità** è espressa come deviazione standard di 10 cariche.

**Umidità relativa** - in condizioni di non condensazione.

**Tempo di stabilizzazione** - in condizioni ambientali ottimali.

\* Wi-Fi® is a registered trademark of Wi-Fi® Alliance.



Extra payment for verification



## Accessori

Cavo seriale RS 232 (connessione bilance - Stampanti)

Lettore di tessere transponder

Cavo seriale RS 232 (connessione bilance - Stampanti ZEBRA)

Cavo seriale RS 232 (connessione bilance - Ethernet)

Display

Cavo seriale RS 232, RS 485

stampanti per etichette

Supporto, set di montaggio a muro e braccetti di montaggio

Tastiera, interruttori esterni

Stampanti di ricevuta

cavo USB (connessione bilance - stampanti)

Moduli aggiuntivi della piattaforma

## Software

- E2R Weighing [WX-010-0099]
- E2R Weighing Records [WX-010-0038]
- Audit Trail Reader [WX-010-0186]
- RADWAG Remote Desktop [WX-010-0107]
- Editore per sistemi di pesatura 2.1 [WX-010-0173]
- E2R Formulazione [WX-010-0043]
- RAD Key [WX-010-0005]
- Editore di etichette R02 [WX-010-0094]
- R-LAB [WX-010-0080]
- Software „Development Studio” RADWAG [WX-010-0104]

## Device dimensions

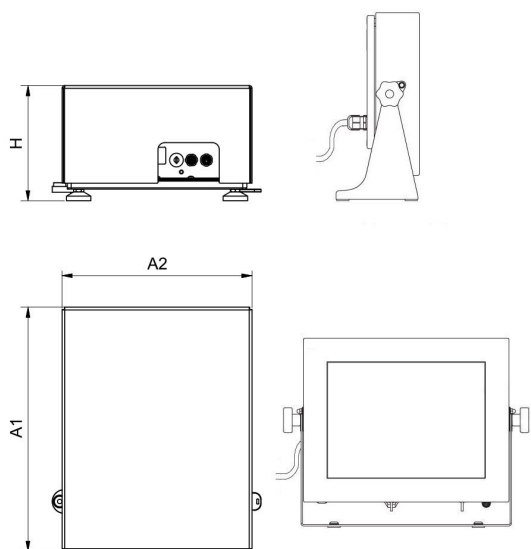

HY10.16 - 32.HRP

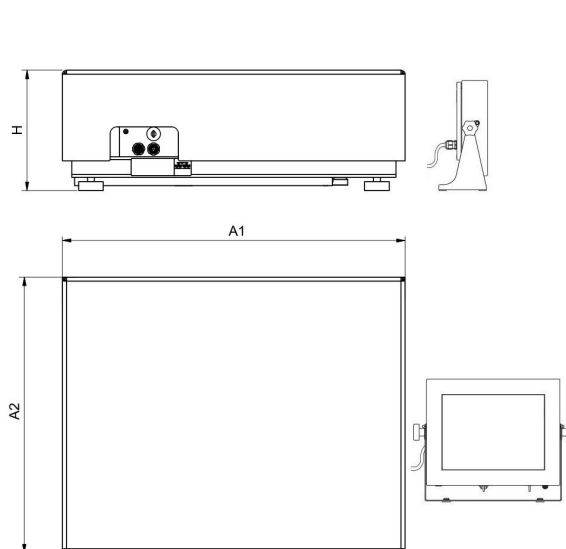

HY10.HRP



PUE HY10

| Scale type            | A1   | A2   | H     |
|-----------------------|------|------|-------|
| HY10.(16-32).HRP      | 360  | 280  | 180±5 |
| HY10.(62-150).HRP     | 500  | 400  | 180±5 |
| HY10.150.2.HRP        | 500  | 500  | 180±5 |
| HY10.(150.1-300).HRP  | 800  | 600  | 180±5 |
| HY10.(300.1-1100).HRP | 1000 | 800  | 180±5 |
| HY10.(2000).HRP       | 1250 | 1000 | 180±5 |

Dimensions in mm