



More information on the website
radwag.com/us/info,w1,17N

PUE 5.19R Weighing Terminal



The drawings, photos and graphics used are for illustrative purposes only.

Functions



Dosing



Labelling



Plus/Minus Control



Parts counting



Formulation



Statistics



Checkweighing

Datasheet

OIML Class	III
Maximum quantity of divisions from converter	8388608
Maximum quantity of verification units	6000 e
Minimum voltage per verification unit	0,4 μ V
Maximum voltage per verification unit	3,25 μ V
Minimum load cell impedance	80 Ω
Maximum load cell impedance	1200 Ω
Load cell excitation voltage	5V
Maximum increase of signal	19,5 mV
Connection of load cells	4 or 6 przewodów

Physical parameters	
Display	19" graphic colour touchscreen
Device dimensions	524×420×200 mm
Packaging dimensions	590×470×240 mm
Net weight	14 kg
Gross weight	16 kg
Construction	
Protection class	IP 67
Touch panel	resistive
Housing	Stainless steel
Communication interface	4×USB 2.0 (2×USB-A, 2×M12 4P), Ethernet - 2×10/100/1000 Mbit (2×RJ45 hermetic), 2×RS232, RS485 (2×M12 8P)
Optional interfaces	external buttons PRINT, TARE, START - terminal with 4IN/4OUT (M12 8P connector) is required, additional weighing platform module - max. 3 pcs, metrological parameters as in the main weighing platform
Power supply	100 – 240 V AC 50/60 Hz
Power consumption max.	75 W
Operating temperature	0 ÷ +40 °C
Storage temperature	-20 ÷ +60 °C
Relative humidity	10% ÷ 85% RH no condensation
Operating system	Microsoft Windows 11
Processor	Intel® Celeron® J6412
Chipset	Intel® UHD Graphics for 10th Gen Intel® Processors
Memory	16 GB RAM
Data memory	SSD 128 GB



Compatible with

Waterproof stainless steel platforms
Mild steel powder coated weighing platforms
Waterproof stainless steel platforms
Stainless steel platforms, pit version
RS 232, RS 485 cables
Mild steel powder coated weighing platforms
Ramp stainless steel platforms
Displays
Platforms in plastic casing

IN/OUT Cables
Stainless steel ramp platforms with LD lifting system
Additional Weighing platforms Module
Keypad, external switches
USB adapter
F1 Mass Standard - knob weights without adjustment chamber, set
RS 232 – USB Converter
Receipt Printer

Software

• Label Editor R02 [WX-010-0094]

Device dimensions

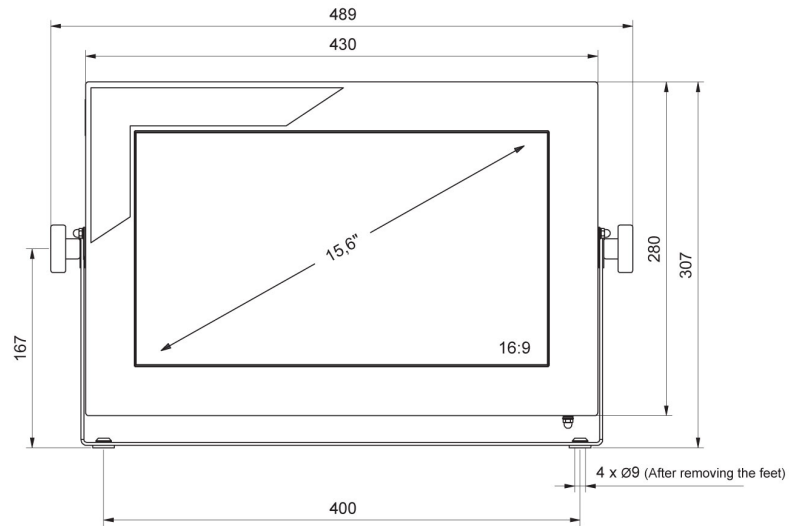
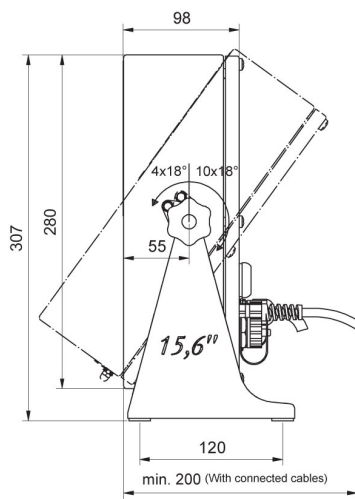

PUE 5.15

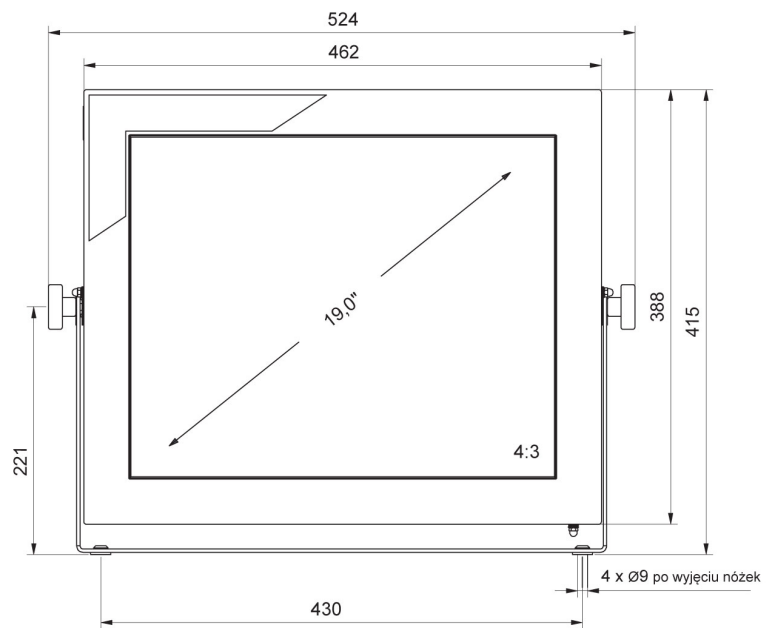
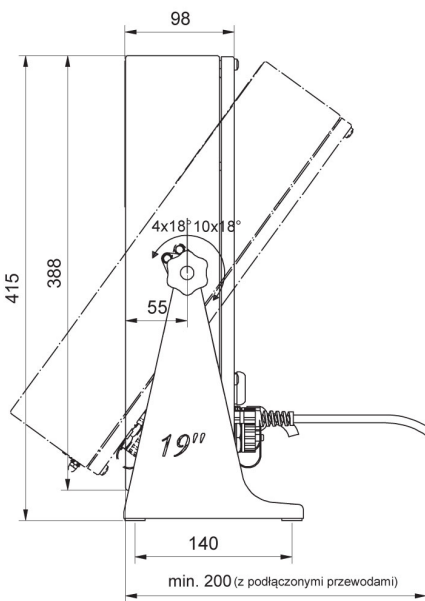

PUE 5.19