



More information on the website  
[radwag.com/us/info,w1,0ZC](http://radwag.com/us/info,w1,0ZC)

# WLC 2.X7 Precision Balance



The drawings, photos and graphics used are for illustrative purposes only.

## Functions

-  Autotest
-  Dosing
-  Percent Weighing
-  Parts counting
-  Peak hold
-  Formulation
-  Newton unit measurement
-  Statistics
-  Checkweighing
-  IR sensors
-  Under-pan weighing
-  GLP Procedures
-  Animal weighing
-  Density determination
-  Ambient conditions monitoring
-  Replaceable unit
-  Statistical Quality Control
-  ALIBI Memory
-  Mass for titrator
-  Wi-Fi

## Datasheet

Maximum capacity [Max]	2 kg
Readability [d]	0,01 g
Verification unit [e]	-
Tare range	-2 kg

Repeatability	0,015 g
Linearity	±0,03 g
Stabilization time	2 s
Adjustment	internal (automatic)
<b>Physical parameters</b>	
Leveling system	manual
Display	7" graphic colour touchscreen
Delivery components	Balance, weighing pan, weighing pan shield, grounding bumper ×1, bumper ×3, power supply.
Weighing pan dimensions	195×195 mm
Packaging dimensions	430×270×190 mm
Net weight	2,2 kg
Gross weight	3,5 kg
<b>Construction</b>	
Protection class	IP 43
Database capacity	7
Communication interface	2×RS232 <sup>1</sup> , USB-A, USB-B, Ethernet, Wi-Fi
Power supply	Adapter: 100 – 240V AC 50/60Hz 0,6A; 12V DC 1,2A Balance: 10 – 15VDC 0,6A max
Operating temperature	+10 ÷ +40 °C

\* Wi-Fi® is a registered trademark of Wi-Fi® Alliance.



## Accessories

!Balance Storage Case  
 Antivibration tables  
 Power Adapters  
 RS 232 cables (scale - printer)  
 Cigarette lighter receptacle power supply cables  
 USB cable (scale - printer)  
 Barcode scanners  
 Under-pan weighing

RS 232, RS 485 cables  
 Density determination KIT  
 Displays  
 Receipt Printer  
 RS 232, RS 485 cables  
 Protective cover for balances  
 RS 232 cables (scale - printer)  
 RS 232 – RS 485 Converter

## Software

- RAD Key [WX-010-0005]
- Scale Editor - EWAG 2.1 [WX-010-0173]

- Alibi Reader PC Software [WX-010-0114]
- RADWAG Development Studio [WX-010-0104]

## Device dimensions

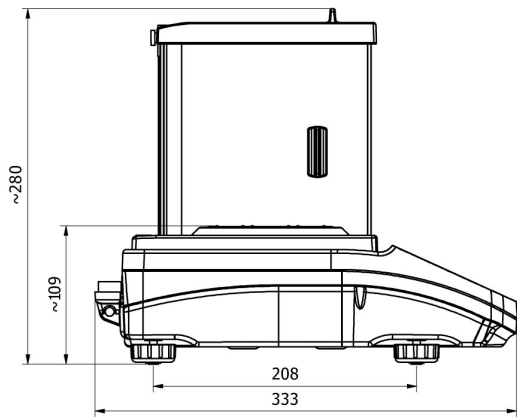

WLC X2, d = 0.001 mg

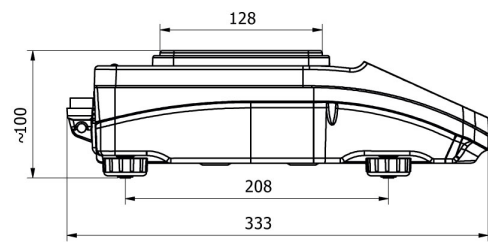
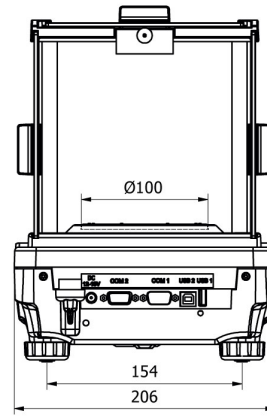

WLC X2, d = 0.01 mg

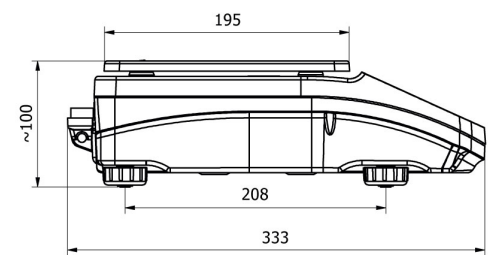
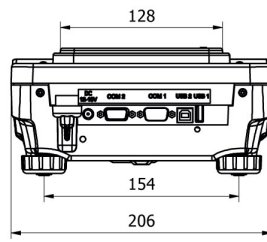

WLC X2, d = 0.1 mg

