



More information on the website
radwag.com/it/info,w1,0TW

Bilancia di precisione PS 10100.R2.M



The drawings, photos and graphics used are for illustrative purposes only.

funzioni



Autotest



Dosing



Percent Weighing



Totalizing



Parts counting



Peak hold



Newton unit measurement



Statistics



Checkweighing



GLP Procedures



Animal weighing



Density determination

Foglio di calcolo

Parametri metrologici	
Capacità massima [Max]	10100 g
Pesata minima	-
Accuratezza	10 mg
Intervallo di verifica della bilancia [e]	-
Intervallo di tara	-10100 g
Ripetibilità standard [5% massimo]	8 mg
Ripetibilità standard [Max]	12 mg

Parametri metrologici	
Peso standard minimo (USP)	10 g
Peso standard minimo (U = 1%, k = 2)	1 g
Linearita	±20 mg
Tempo di stabilizzazione	1,5 s
Calibrazione	internal (automatic)
Classe OIML	-
Sensibilita di variazione della temperatura	$2 \times 10^{-6} / ^\circ\text{C} \times \text{Rt}$
Parametri fisici	
Sistema di livellamento	manualny
Display	LCD (backlit)
Componenti del kit	Balance, weighing pan, weighing pan shield, power supply
Dimensioni del piatto di pesata	195x195 mm
Device dimensions	333x206x107 mm
Dimensioni del pacco	475x380x345 mm
Peso netto	4,5 kg
Peso lordo	5,5 kg
Costruzione	
Punteggio IP	IP 43
Interfaccia di comunicazione	
Interfaccia	2xRS232 ¹ , USB-A, USB-B, Wi-Fi (option)
Parametri elettrici	
Alimentatore	Adapter: 100 – 240V AC 50/60Hz 0,6A; 12V DC 1,2A Balance: 12 – 15V DC 0,4A max
Consumo di energia	4 W
Environmental conditions	
Temperatura di lavoro	+10 ÷ +40 °C
Temperatura di stoccaggio	-20 ÷ +50 °C
Umidita atmosferica	40% ÷ 80%

* Wi-Fi® is a registered trademark of Wi-Fi® Alliance.



Accessori

Contenitore per stoccaggio bilance
Tavoli antivibranti
Alimentatore
Cavo di alimentazione con spina per accendisigari
cavo USB (connessione bilance - stampanti)
Lettore di codici a barre
Cavo seriale RS 232, RS 485

Display
KIT determinazione della densita
Capottina protettiva per bilance
Stampanti di ricevuta
Cavo seriale RS 232, RS 485
Under-pan weighing
Cavo seriale RS 232 (connessione bilance - Stampanti)

Software

- RAD Key [WX-010-0005]
- „Alibi Reader“ PC Software [WX-010-0114]
- Software „Development Studio“ RADWAG [WX-010-0104]
- R Panel [WX-010-0187]
- R-LAB [WX-010-0080]

Device dimensions

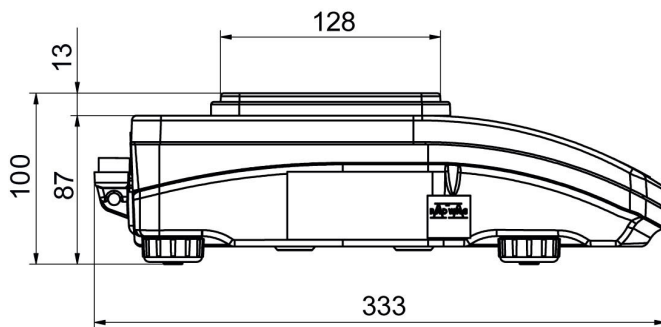

PS R, d = 1mg

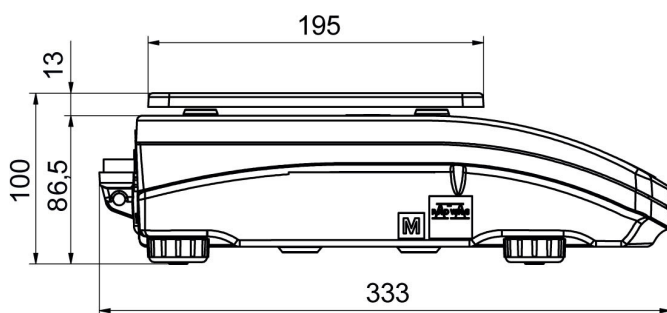
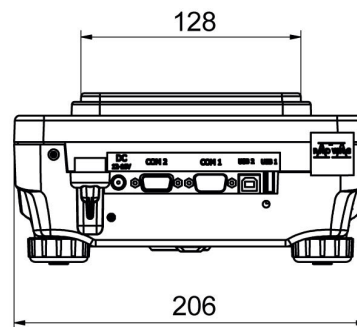

PS R, d = 10 mg

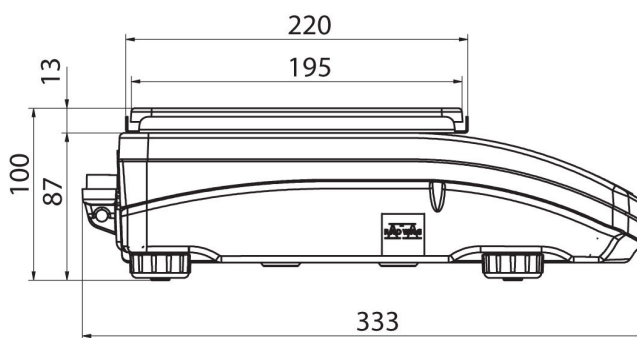
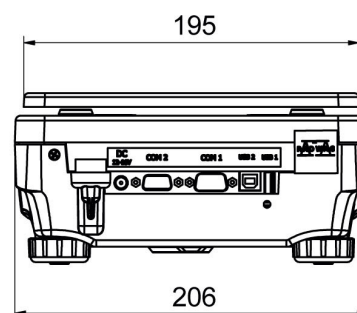

PS R.M, d = 10 mg

