



More information on the website
radwag.com/us/info,w1,0SA

MWMH 100-2 Electromagnetic Compensation Weighing Module



The drawings, photos and graphics used are for illustrative purposes only.

Datasheet

Maximum capacity [Max]	1 kg
Minimum load	2 g
Preload range	6 - 9 kg
Readability [d]	0,01 g
Verification unit [e]	0,1 g
Tare range	-1 kg
Repeatability	0,01 g
Stabilization time	0,1 s
Adjustment	external
OIML Class	III
Sensitivity temperature drift	$2 \times 10^{-6} / ^\circ\text{C} \times \text{Rt}$
Construction	
Protection class	IP 65
Material	Stainless steel

Communication interface	RS232, Ethernet, 2×IN / 2×OUT
Power supply	12 ÷ 24 V DC
Power consumption max.	5 W
Operating temperature	+10 ÷ +40 °C
Storage temperature	-20 ÷ +50 °C
Relative humidity	15% ÷ 80%
Physical parameters	
Weighing pan dimensions	212×174 mm
Device dimensions	344×224×166 mm
Packaging dimensions	580×413×360 mm
Net weight	12,4 kg
Gross weight	15 kg



Accessories

RS 232 – USB Converter

Software

- MWMH Manager [WX-010-0103]
- Scale Editor - EWAG 2.1 [WX-010-0173]
- RAD Key [WX-010-0005]
- RADWAG Development Studio [WX-010-0104]

Device dimensions

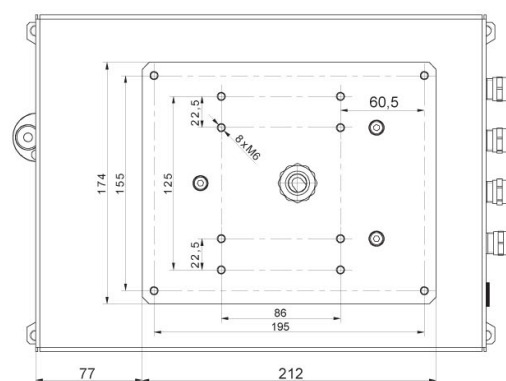
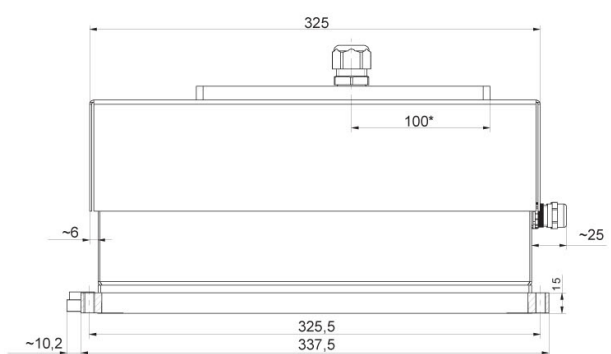
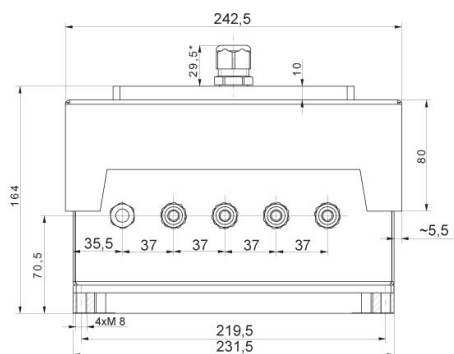

MWMH IP 69K